

MOSFETs: Gradual Channel Approximation

Gradual channel approximation

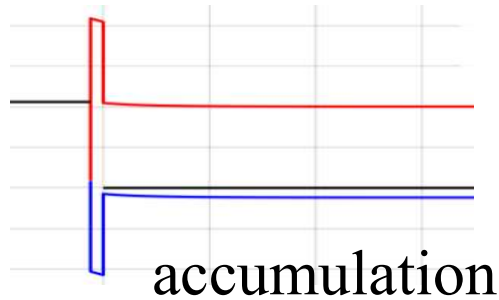

$$Q_{\text{mobile}} = \begin{cases} 0, & \text{for } V_G - V_B < V_T \\ -C_{\text{ox}}(V_G - V_B - V_T) & \text{for } V_G - V_B > V_T \end{cases}$$

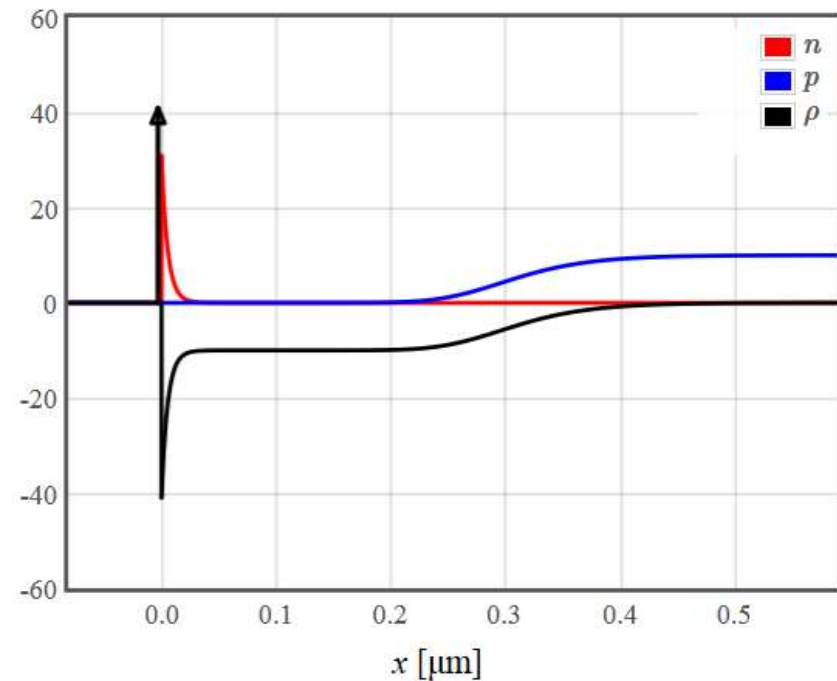
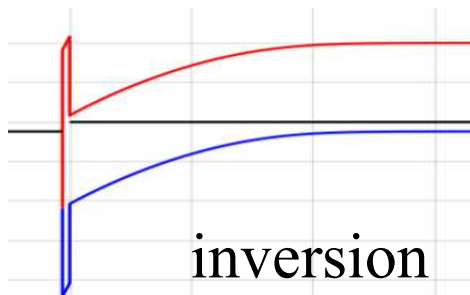
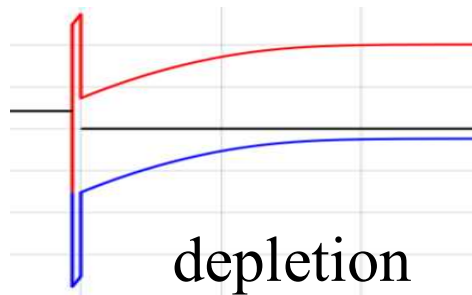

<http://lampx.tugraz.at/~hadley/psd/L10/gradualchannelapprox.php>

Gradual channel approximation

Ohm's law $\longrightarrow j = -nev_d = ne\mu_n E_y$

$$I = Ztj = Ztne\mu_n E_y = Ze\mu_n n_s E_y$$

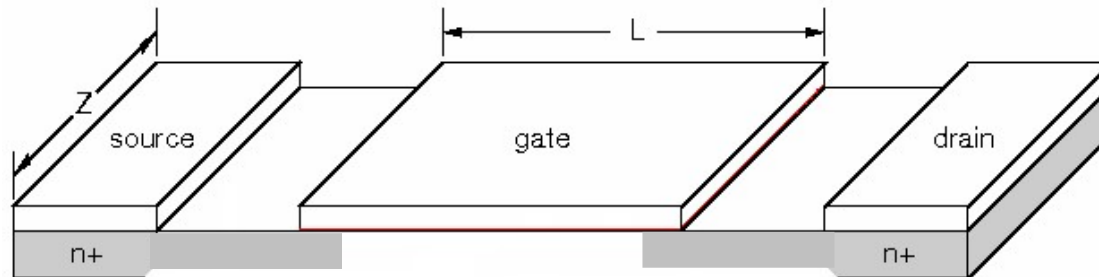

$n_s = nt$ is the sheet charge at the interface.

$$n_s(y) = -\frac{Q}{e} = \frac{C_{ox} (V_G - V_{ch}(y) - V_T)}{e}$$

Gradual channel approximation

$$n_s(y) = -\frac{Q(y)}{e} = \frac{C_{ox}(V_G - V_{ch}(y) - V_T)}{e}$$

$$I = Ztj = Ztnev_d = Zen_s\mu_n E_y$$

$$I_D = -Z\mu_n C_{ox}(V_G - V_{ch}(y) - V_T) \frac{dV_{ch}}{dy}$$

differential equation for V_{ch}

Gradual channel approximation

$$V_{ch}(y) = V_G - V_T - \sqrt{(V_G - V_T)^2 - \frac{2I_D y}{Z\mu_n C_{ox}}}$$

$$E_y = -\frac{dV_{ch}}{dy} = -\frac{I_D}{Z\mu_n C_{ox} \sqrt{(V_G - V_T)^2 - \frac{2I_D y}{Z\mu_n C_{ox}}}}$$

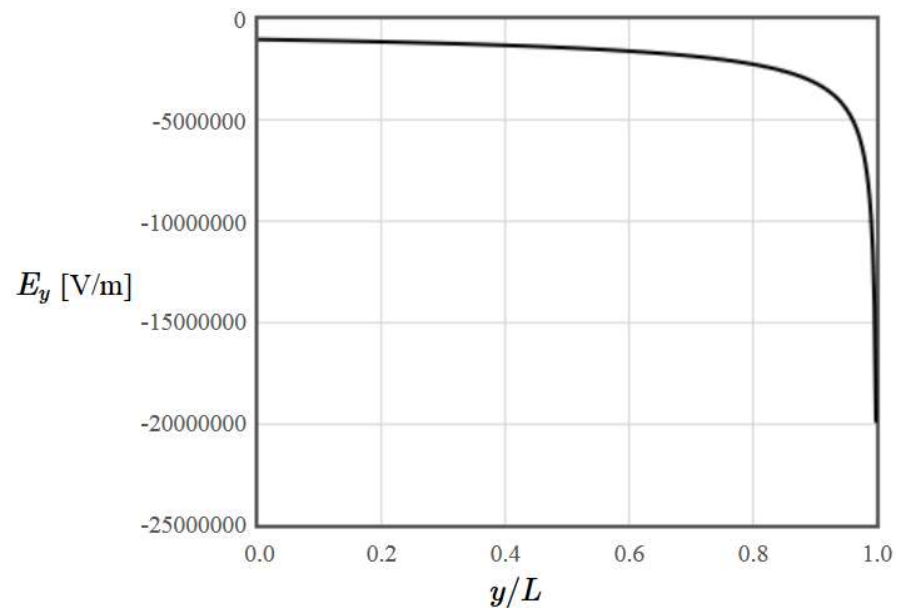
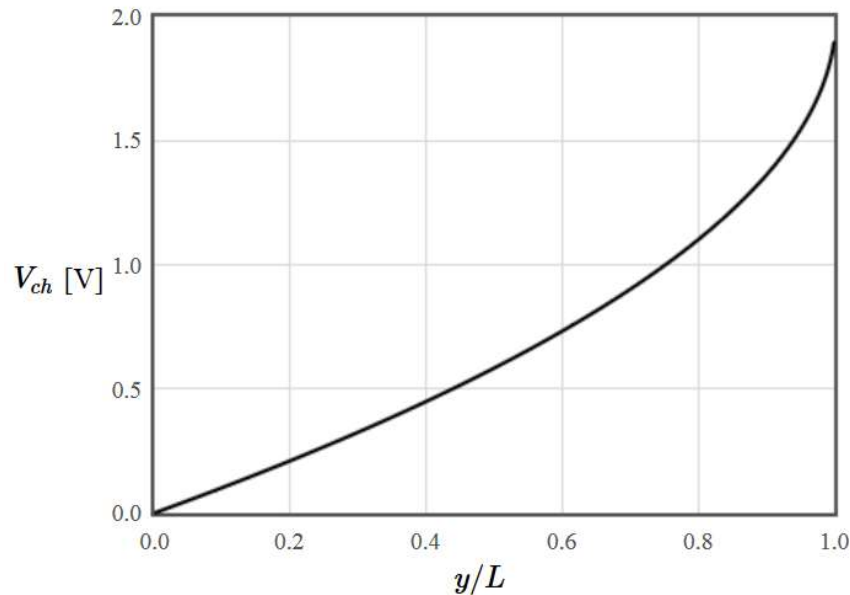

MOSFET Gradual Channel Approximation

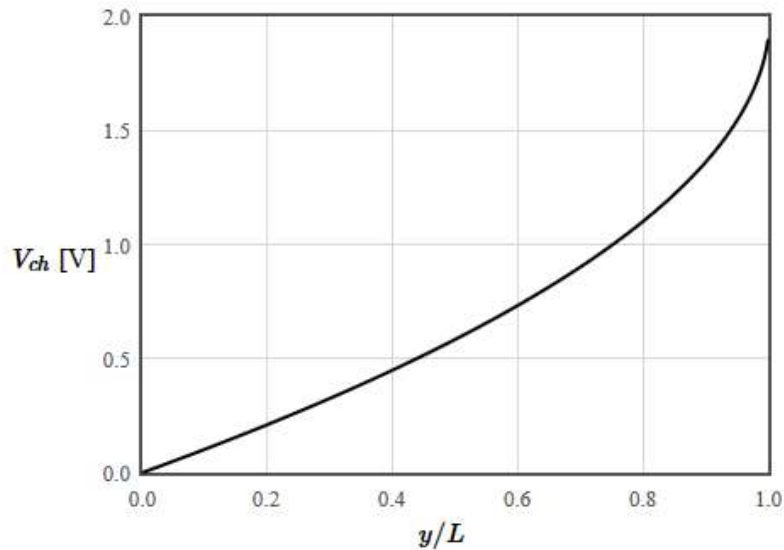

Z	<input type="text" value="1E-5"/>	m
L	<input type="text" value="1E-6"/>	m
μ_n	<input type="text" value="1500"/>	cm ² /Vs
ϵ_r	<input type="text" value="4"/>	
t_{ox}	<input type="text" value="3E-9"/>	m
V_D	<input type="text" value="1.9"/>	V
V_G	<input type="text" value="3"/>	V
V_T	<input type="text" value="1"/>	V
<input type="button" value="Replot"/>		

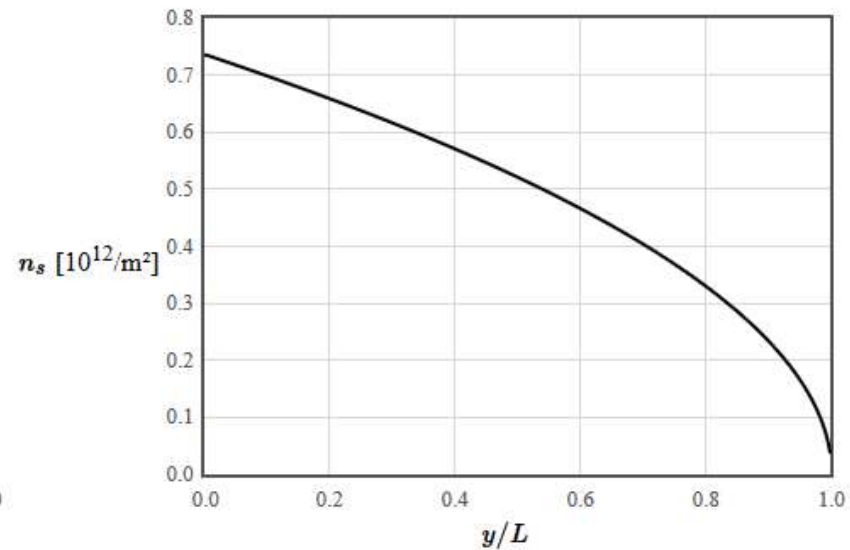
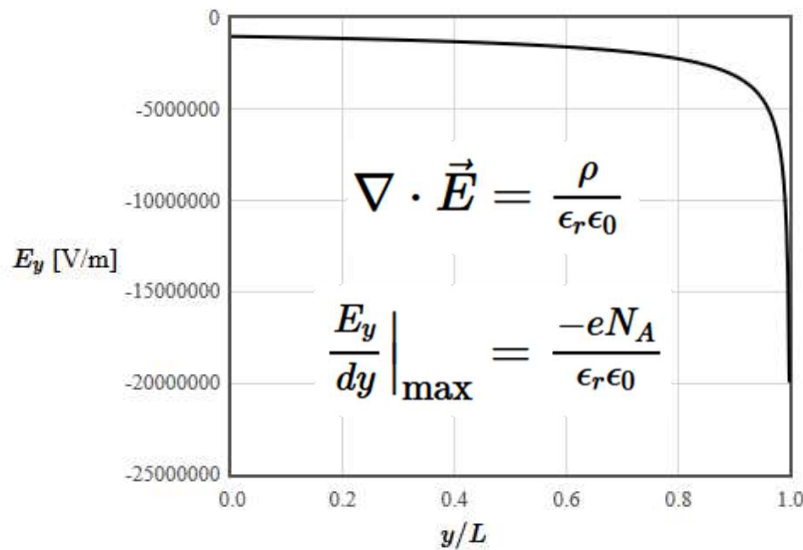

MOSFET (saturation regime)

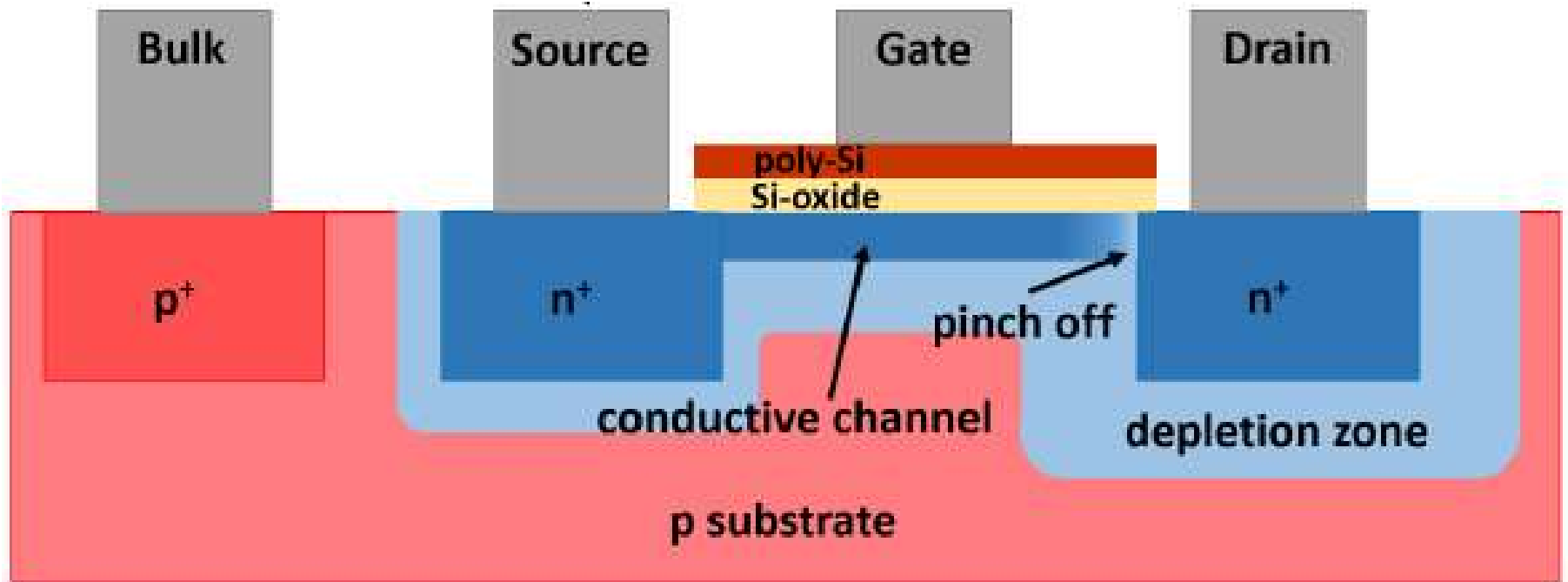

Gradual channel approximation

$$\int_0^L I_D dy = \int_0^{V_D} Z \mu_n C_{ox} (V_G - V_{ch}(y) - V_T) dV$$

$$I_D = \frac{Z}{L} \mu_n C_{ox} \left[(V_G - V_T) V_D - \frac{V_D^2}{2} \right]$$

Valid in the linear regime (until pinch-off occurs at the drain).

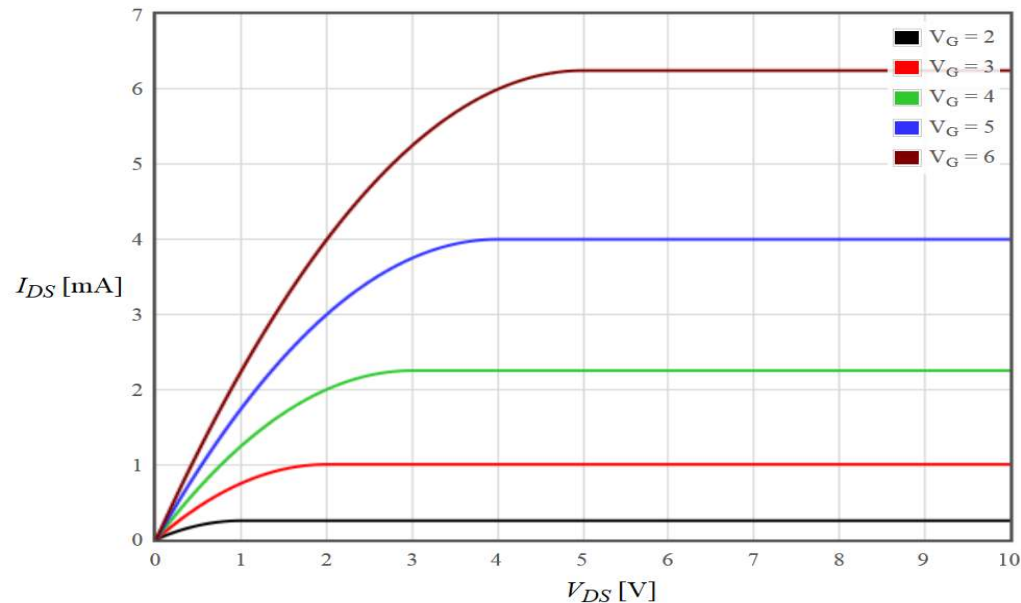

MOSFET-saturation voltage

$$I = \frac{Z}{L} \mu_n C_{ox} \left[(V_G - V_T) V_D - \frac{V_D^2}{2} \right]$$

At pinch-off, $dI_{ds}/dV_{ds} = 0$

$$\frac{dI}{dV_D} = \frac{Z}{L} \mu_n C_{ox} \left[(V_G - V_T) - V_D \right] = 0 \quad V_{sat} = (V_G - V_T)$$

A MOSFET in saturation is a voltage controlled current source.

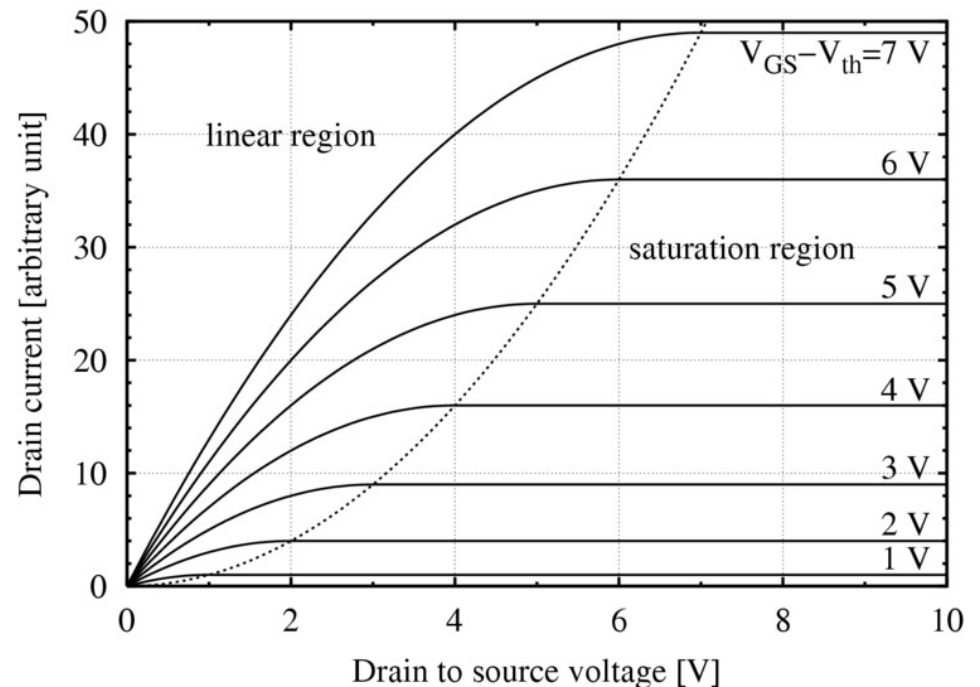

MOSFET - saturation current

Use the saturation voltage at pinch-off to determine the saturation current

$$V_{sat} = (V_G - V_T)$$

$$I = \frac{Z}{L} \mu_n C_{ox} \left[(V_G - V_T) V_D - \frac{V_D^2}{2} \right]$$

$$I_{sat} = \frac{Z}{2L} \mu_n C_{ox} (V_G - V_T)^2$$

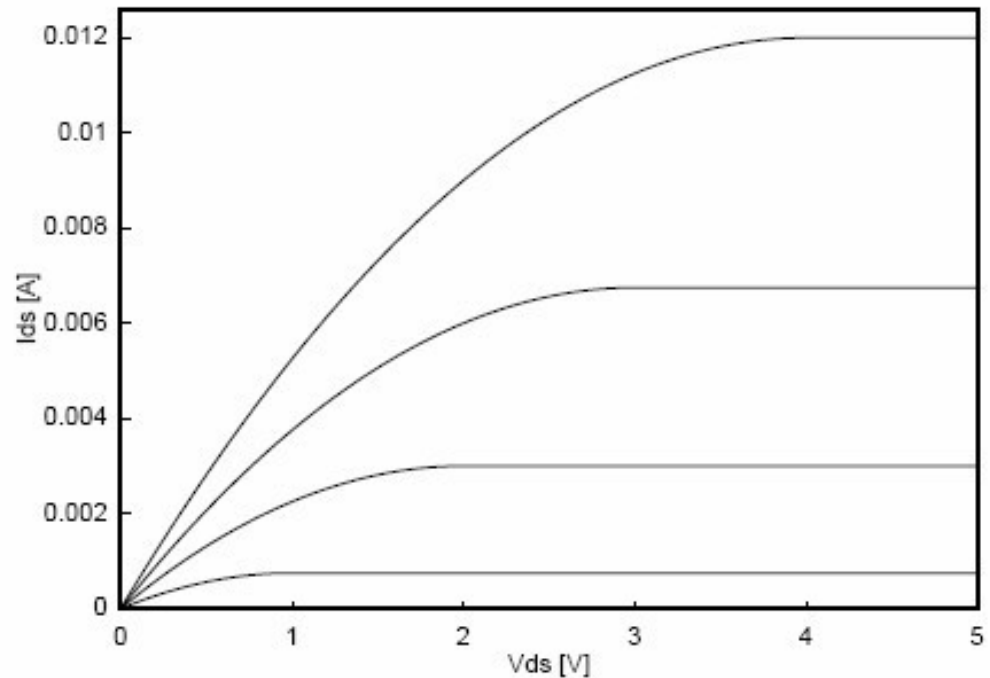

MOSFET (saturation regime)

$$I_{sat} = \frac{Z}{2L} \mu_n C_{ox} (V_{GS} - V_T)^2$$

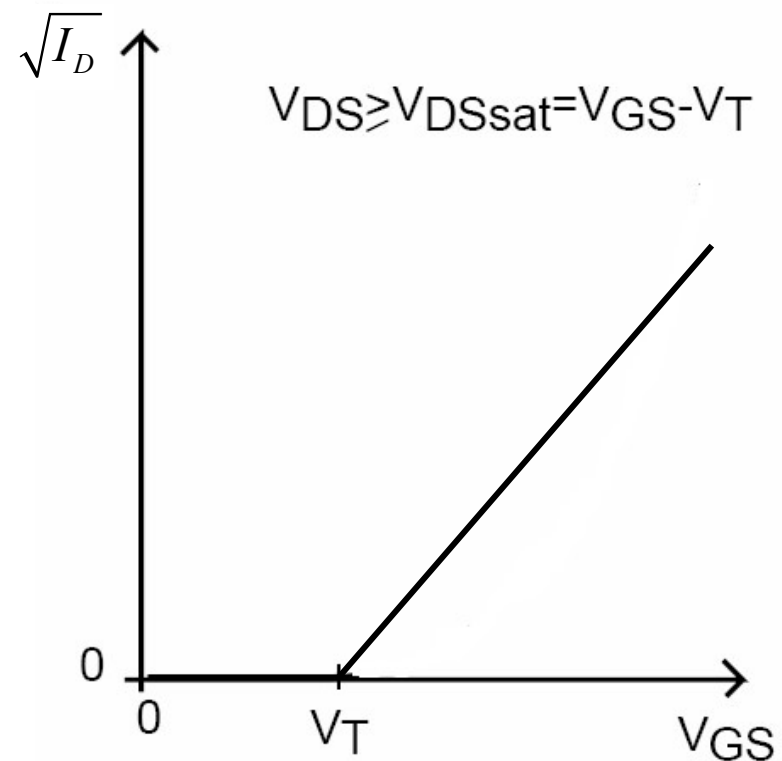
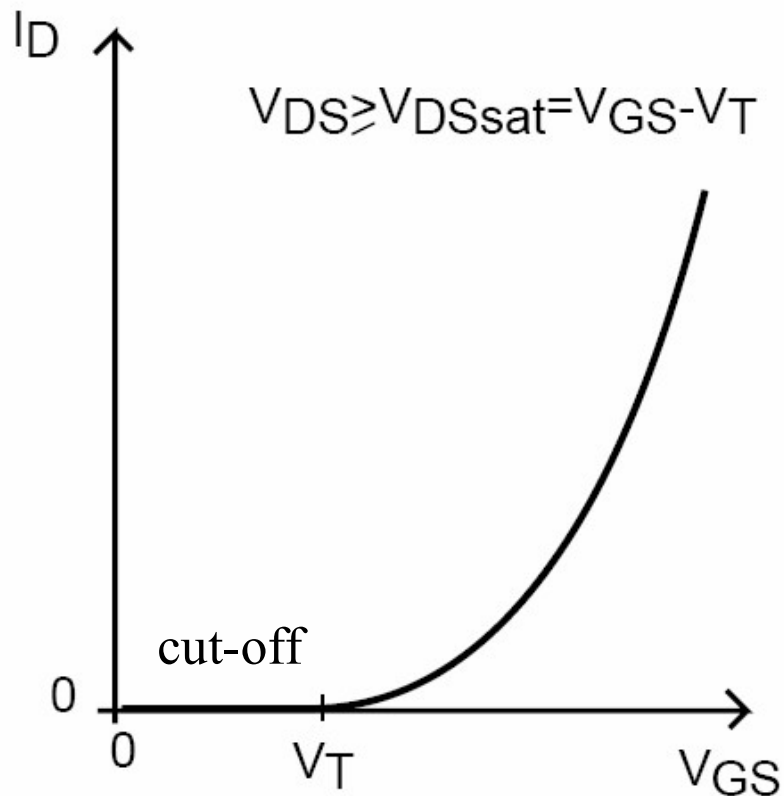
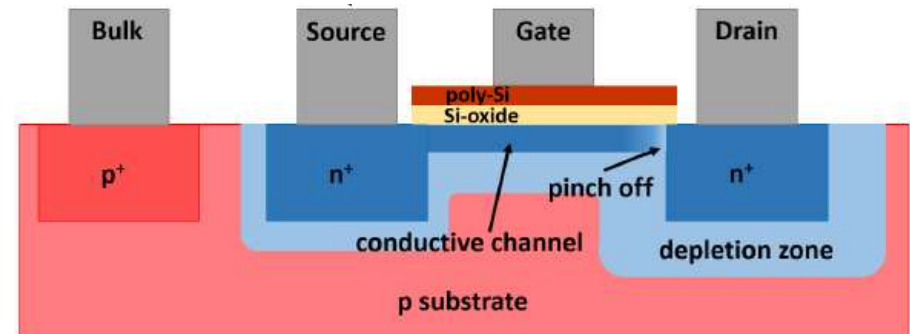

MOSFET (linear regime)

Channel conductance in the linear regime. For small V_D

$$I \approx \frac{Z}{L} \mu_n C_{ox} [(V_G - V_T) V_D]$$

$$g_D = \frac{dI_D}{dV_D} = \frac{Z}{L} \mu_n C_{ox} (V_G - V_T)$$

Transconductance

$$g_m = \frac{dI_D}{dV_G} = \frac{Z}{L} \mu_n C_{ox} V_D$$

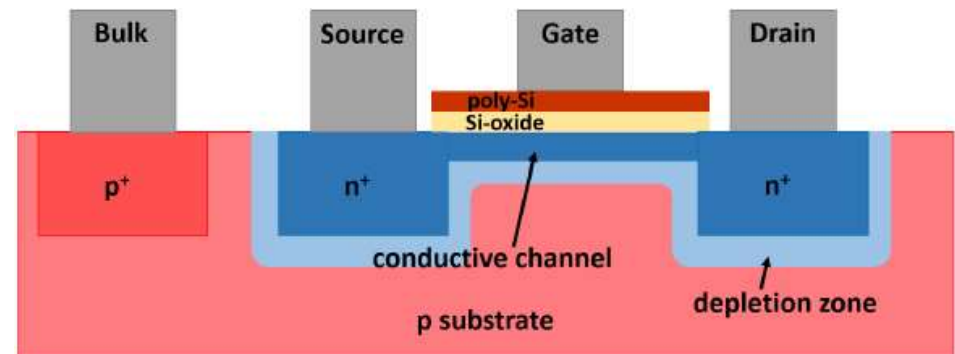
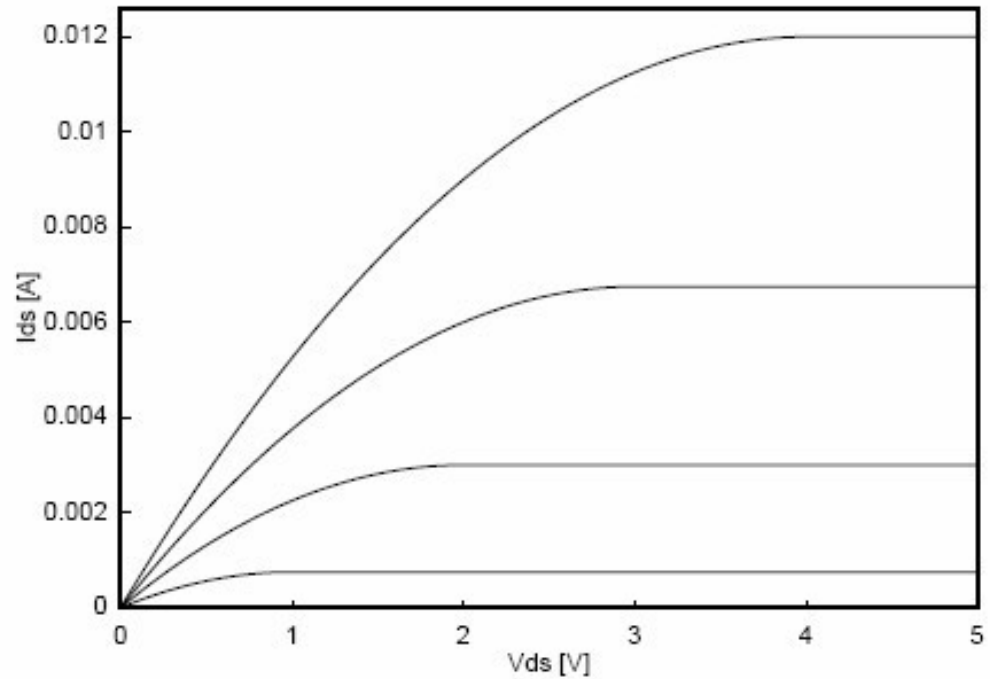

MOSFET (saturation regime)

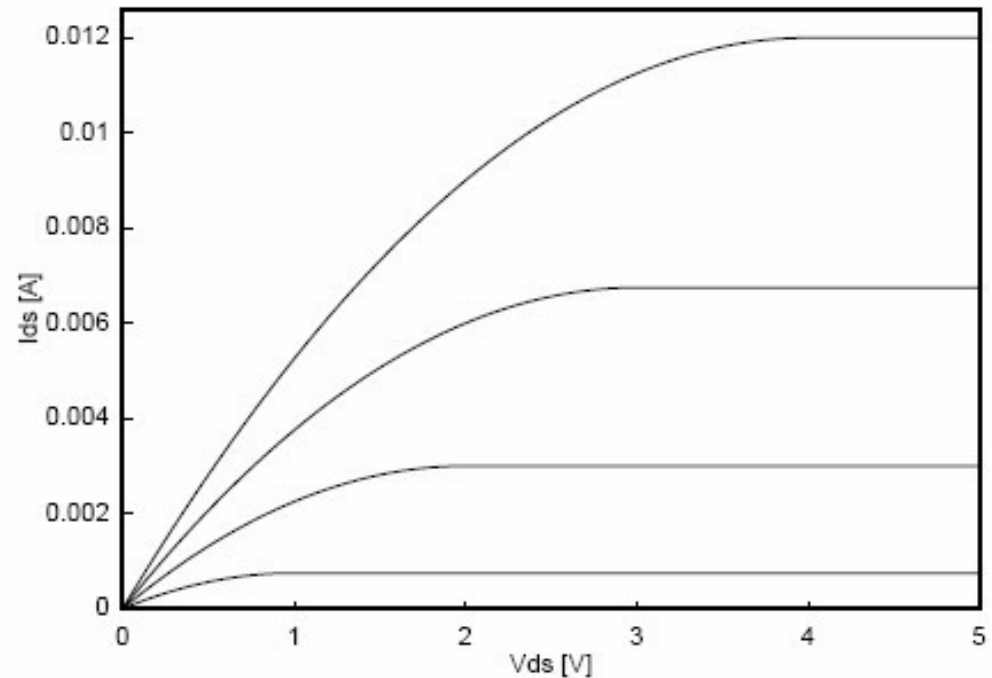
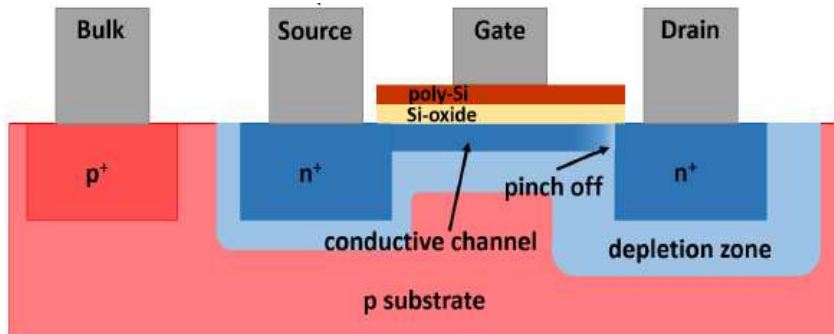

$$I_{sat} = \frac{Z}{2L} \mu_n C_{ox} (V_G - V_T)^2$$

Transconductance

$$g_m = \frac{dI_D}{dV_G} = \frac{Z}{L} \mu_n C_{ox} (V_G - V_T)$$

A MOSFET in the saturation regime acts like a voltage controlled current source.

Saturation

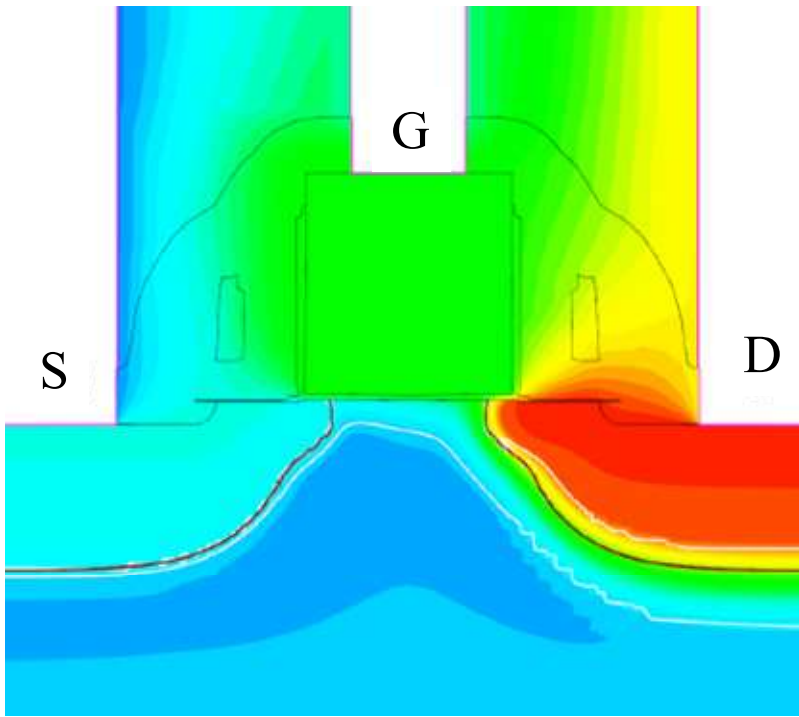

Potential

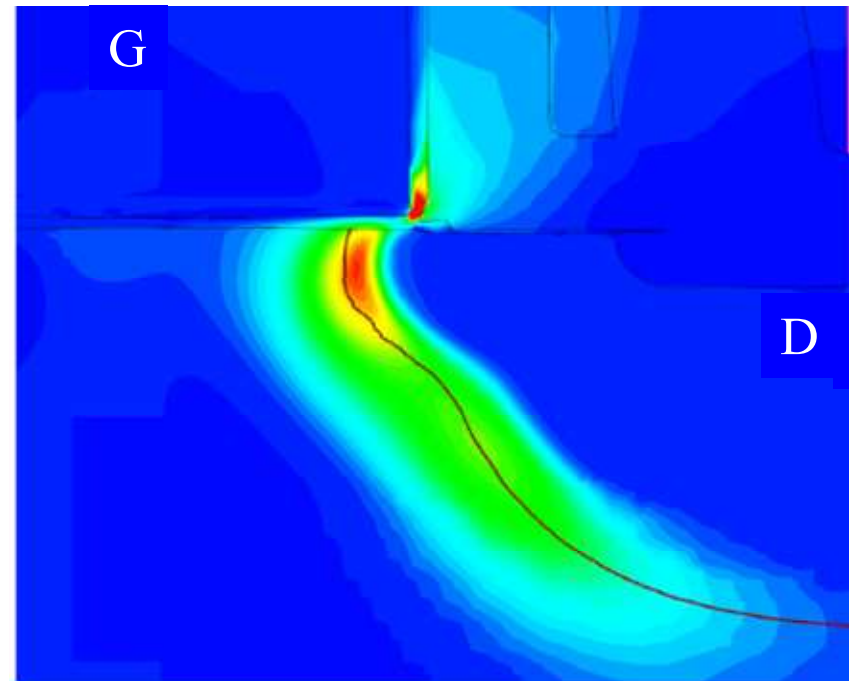

Electric field strength

MOSFET (saturation regime)

$$I_{sat} = \frac{Z}{2L} \mu_n C_{ox} (V_G - V_T)^2 (1 - \lambda (V_D - V_{sat}))$$

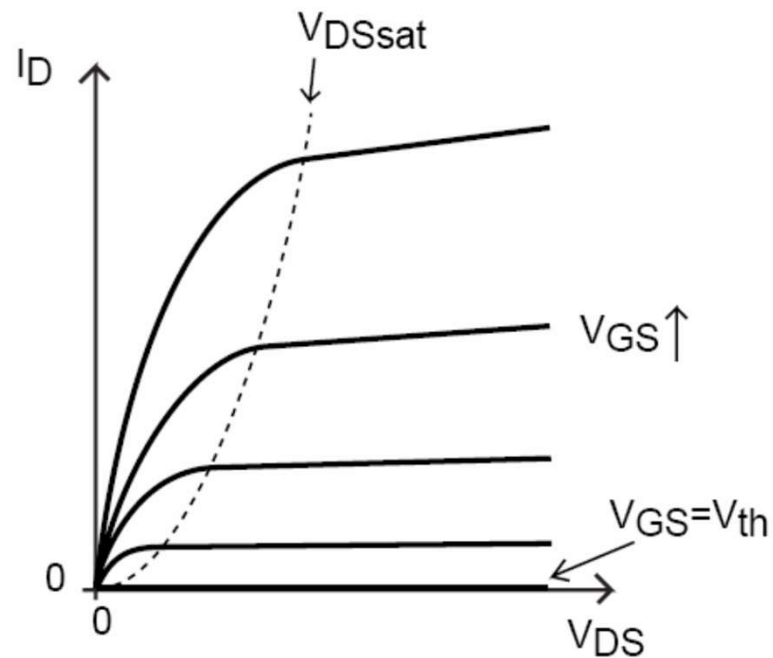

Experimentally: channel length modulation

$$\lambda \propto \frac{1}{L}$$

High frequencies

$$\tilde{i}_{in} = 2\pi f C_G \tilde{v}_G$$

$$\tilde{i}_{out} = g_m \tilde{v}_G$$

$$\tilde{i}_{in} < \tilde{i}_{out}$$

$$f < \frac{g_m}{2\pi C_G} \propto \frac{1}{L^2} = f_T$$

For large E , Ohm's law ($j = ne\mu E$) is not valid. The electron velocity saturates. For velocity saturation:

$$f_T \approx \frac{v_s}{L}$$

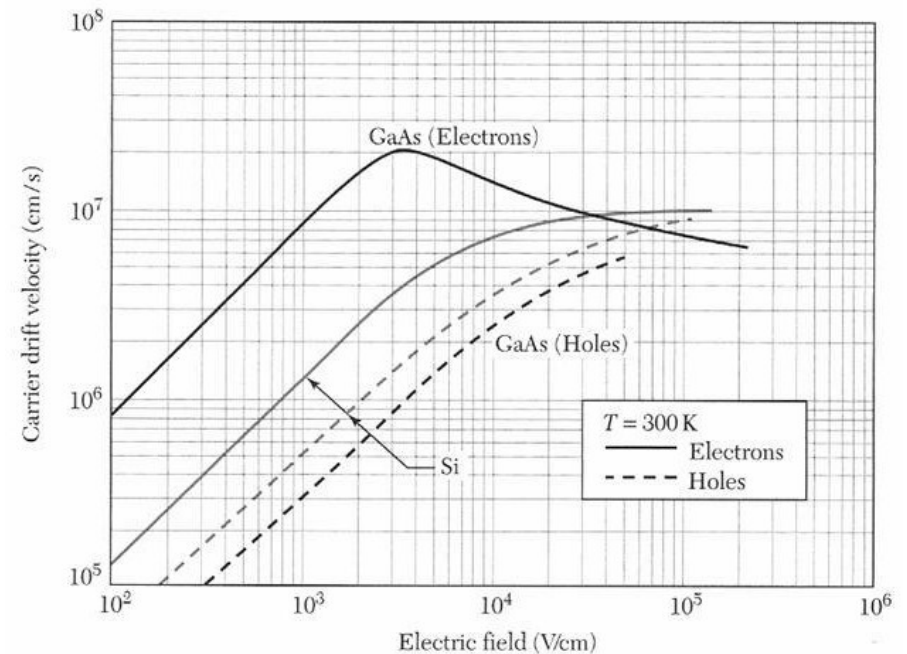

CMOS inverter

Dissipates little power
except when switching

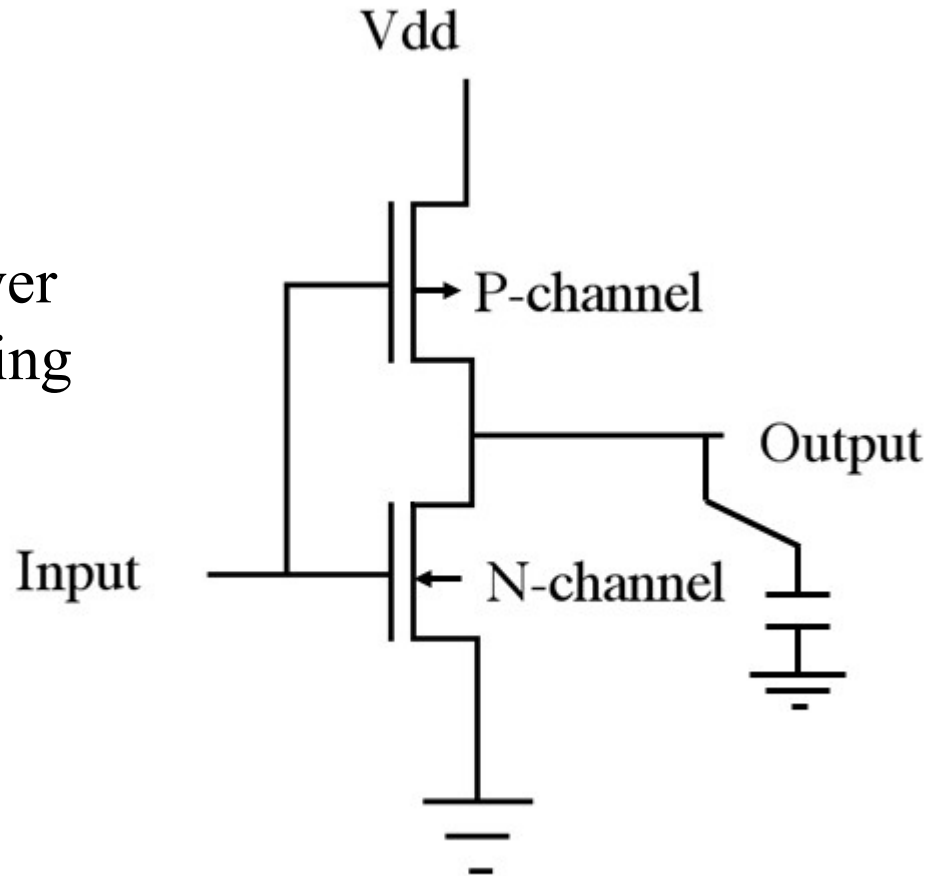

$$E = QV_{dd} = CV_{dd}^2$$

Gate delay

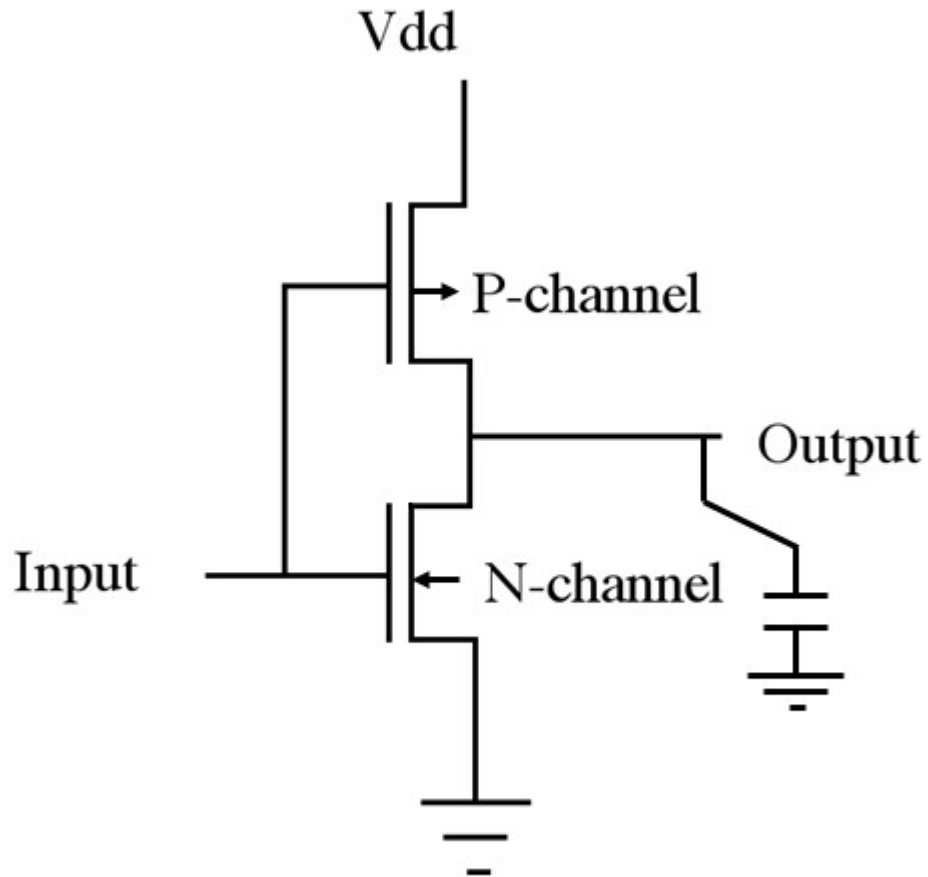

Gate delay is limited by $C_{gate}V_{dd}/I$.

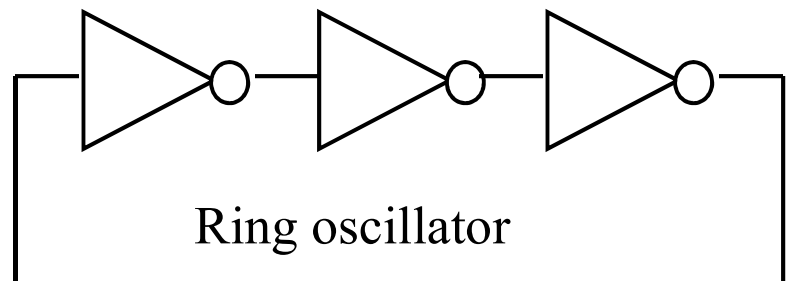

CMOS inverter

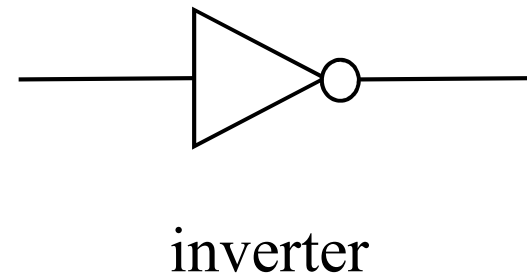
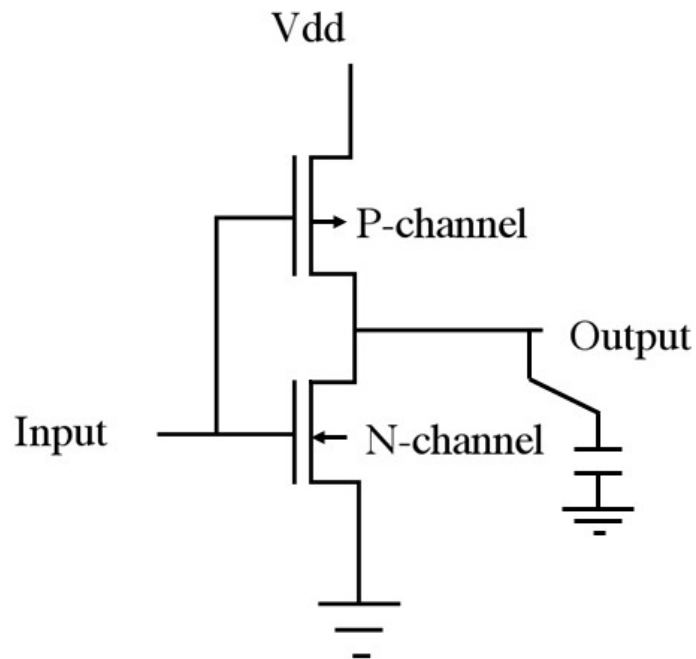
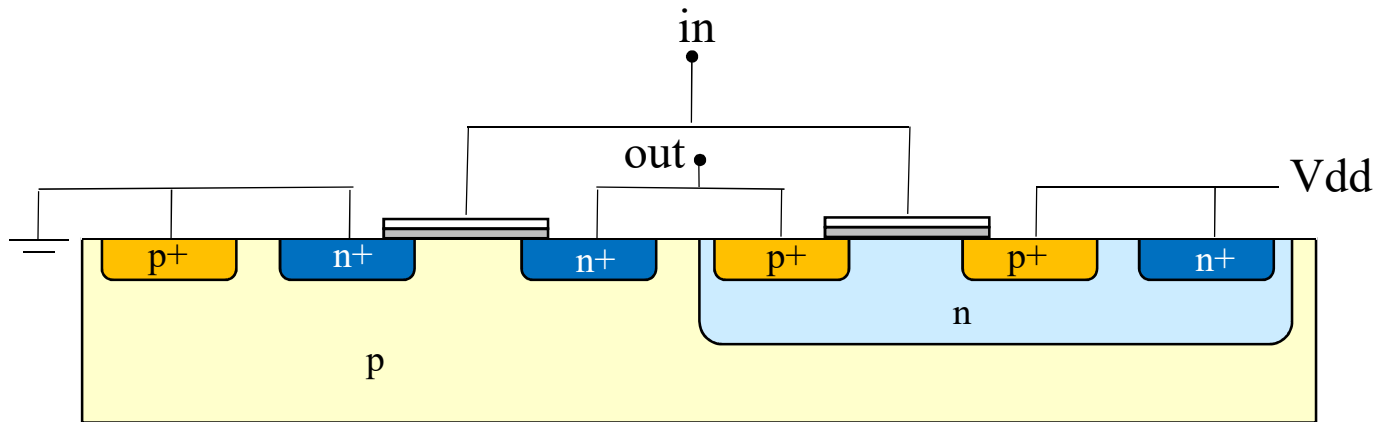

CMOS inverter

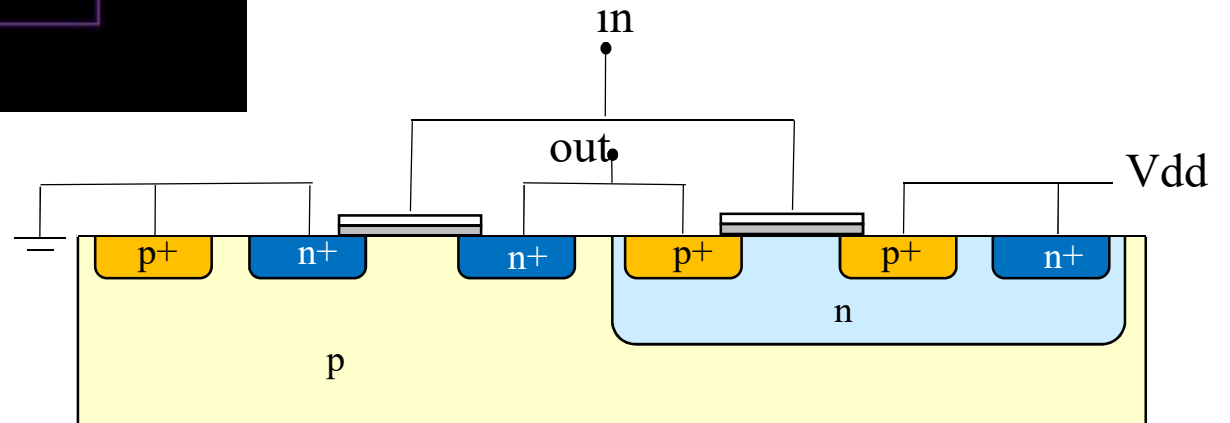
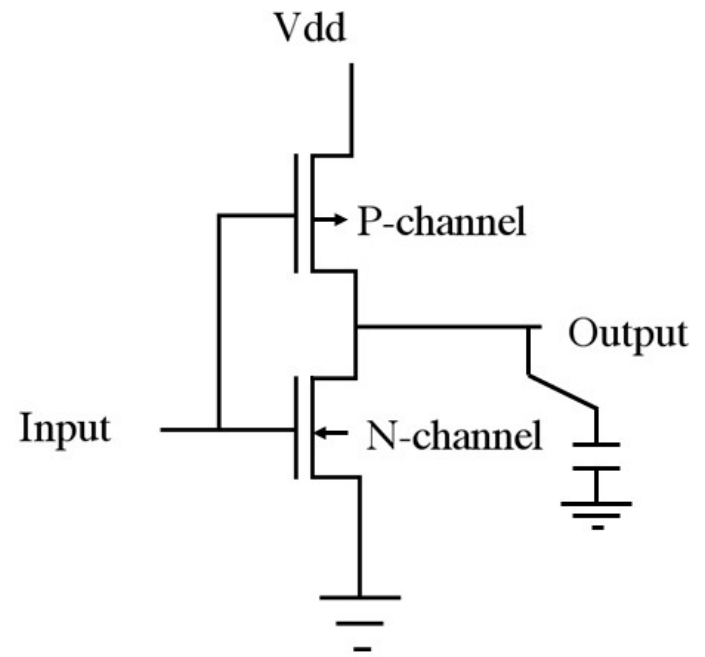
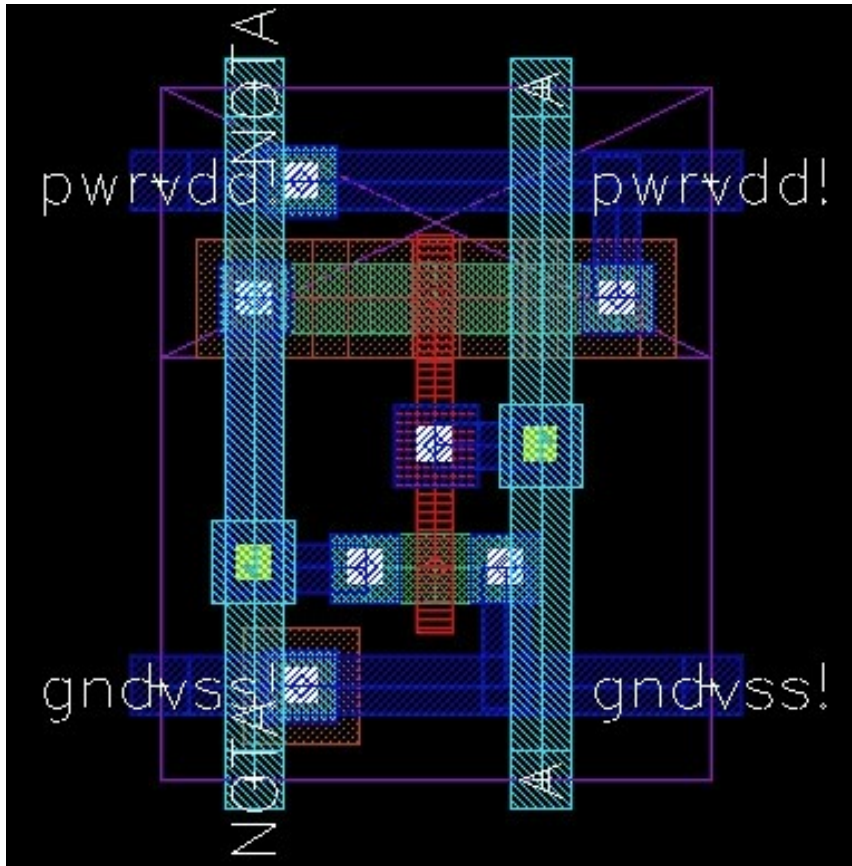

Constant E-field Scaling

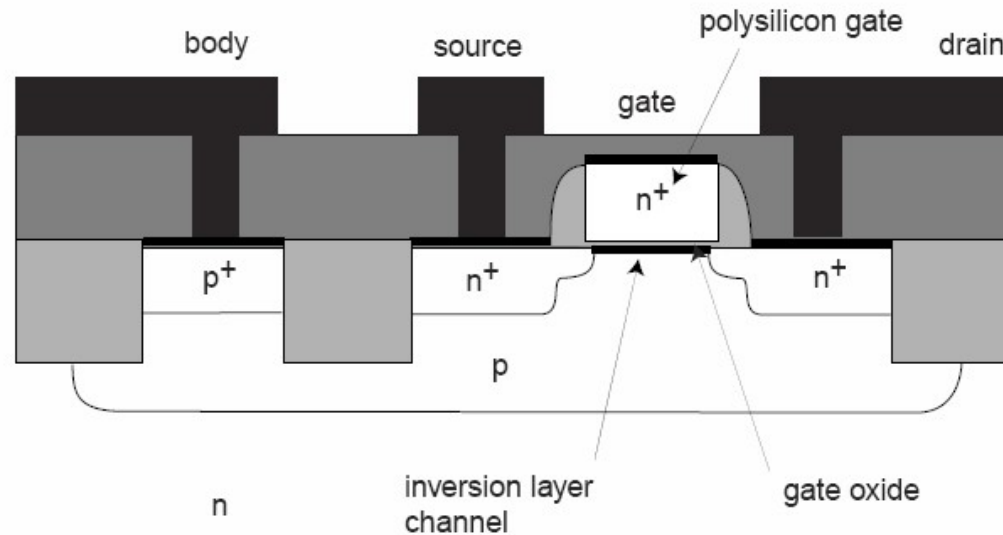

Gate length L , transistor width Z , oxide thickness t_{ox} are scaled down.

V_{ds} , V_{gs} , and V_T are reduced to keep the electric field constant.

Power density remains constant.

$$L \sim 45 t_{ox}$$

1975 - 1990: "Days of happy scaling"

Constant E-field scaling

$$I_{sat} = \frac{Z}{2L} \mu_n \frac{\epsilon_{ox}}{t_{ox}} (V_G - V_T)^2$$

$$L \Rightarrow sL, \quad Z \Rightarrow sZ, \quad t_{ox} \Rightarrow st_{ox}, \quad V_{th} \Rightarrow sV_{th}$$

$$I_{sat} \Rightarrow sI_{sat} \quad \longleftarrow \quad I_{sat} \text{ gets smaller}$$

$$g_m = \frac{dI_D}{dV_G} = \frac{Z}{L} \mu_n \frac{\epsilon_{ox}}{t_{ox}} (V_G - V_T) \quad \longleftarrow \quad \text{Transconductance stays the same.}$$

Power per transistor decreases like L^2 . Power per unit area remains constant.

The heat dissipation problem

Microprocessors are hot ~ 100 C

Hotter operation will cause dopants to diffuse

When more transistors are put on a chip they must dissipate less power.

Power per transistor decreases like L^2 .

Dual stress liners

DUAL STRESS LINER TRANSISTOR CROSS-SECTION

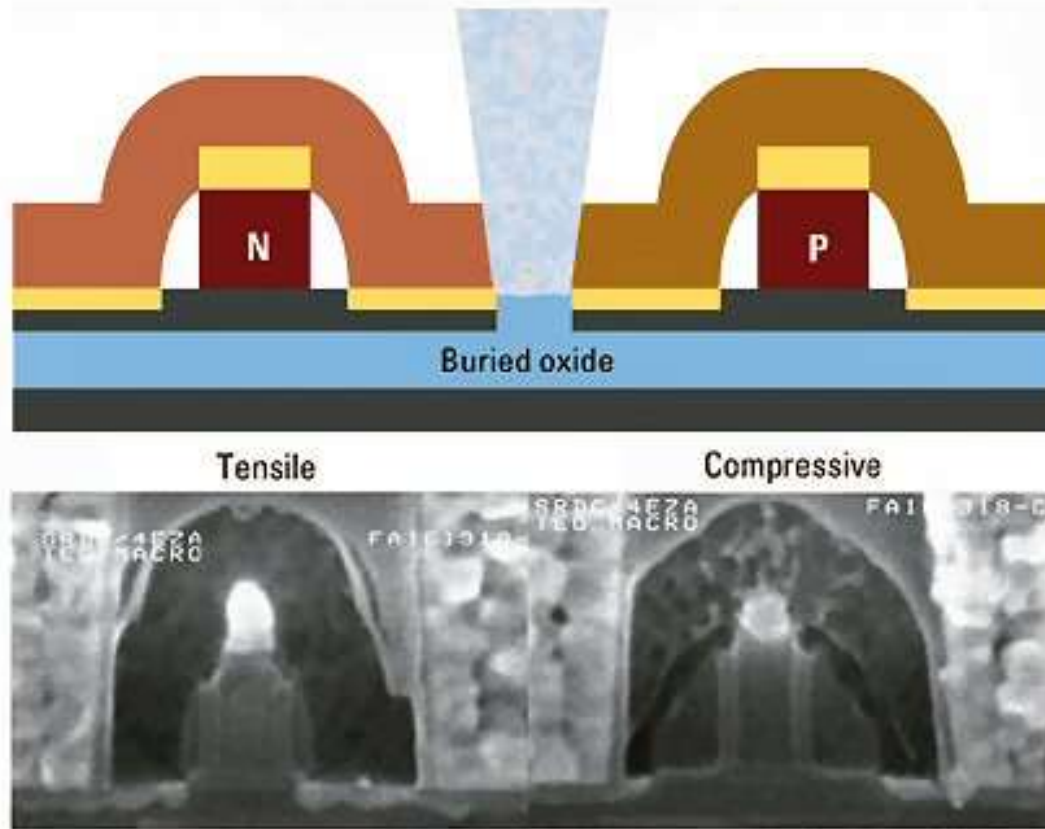

Tensile silicon nitride film over the NMOS and a compressive silicon nitride film over the PMOS improves the mobility.

Gate dielectric

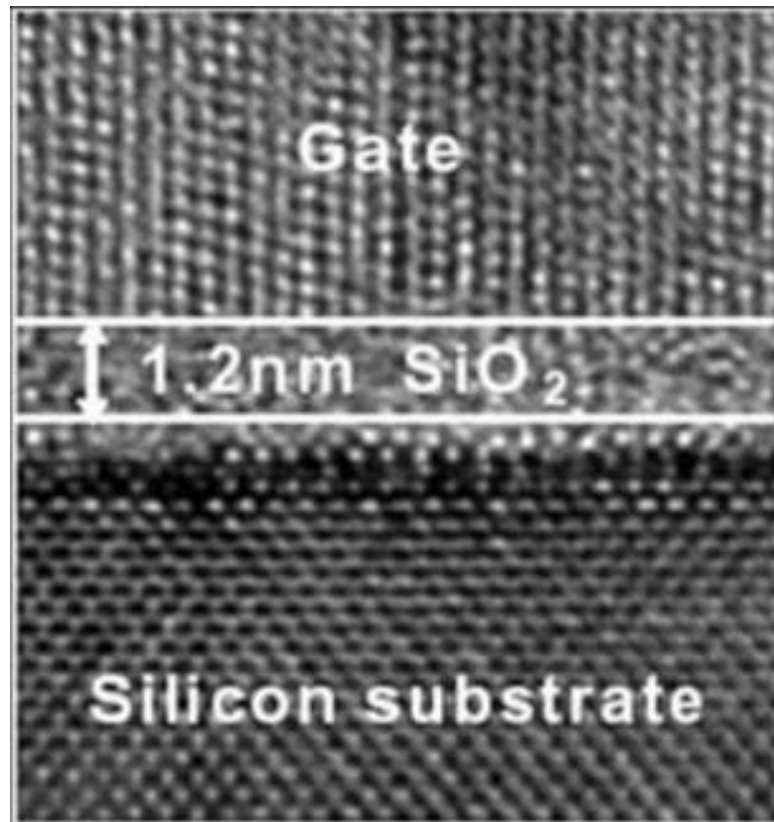

Thinner than 1 nm:
electrons tunnel

Large dielectric
constant desirable
 $\epsilon_r(\text{SiO}_2) \sim 4$

$\epsilon_r(\text{Si}_3\text{N}_4) \sim 7$

High-k dielectrics

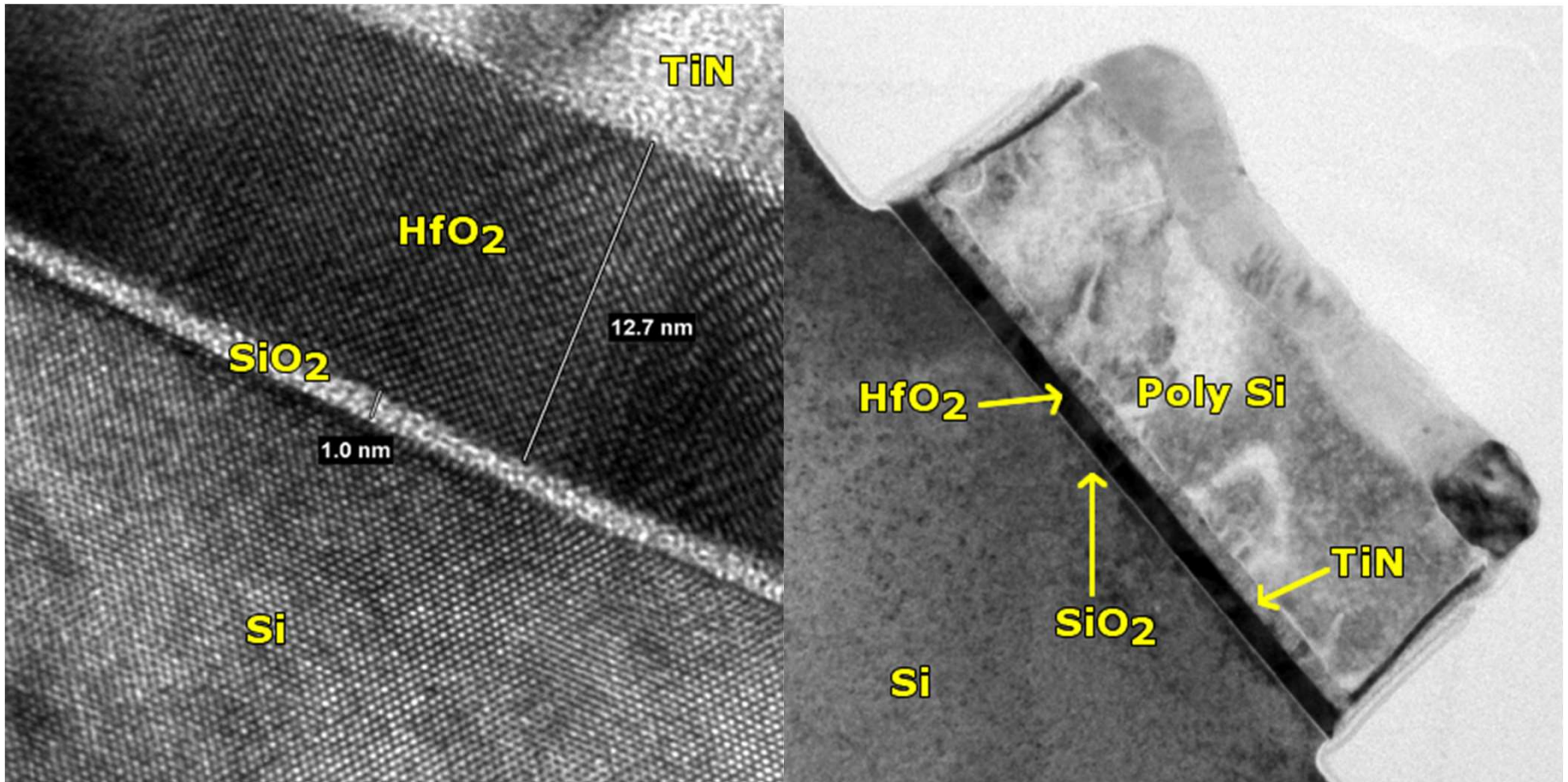

Short channel effects

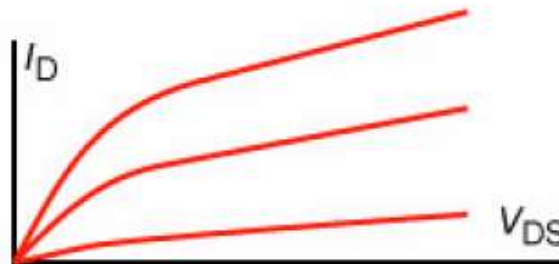
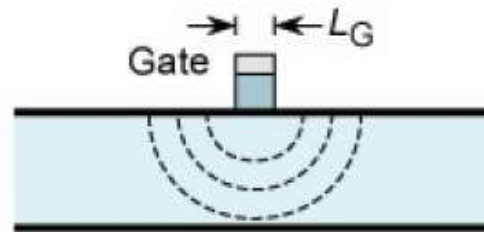
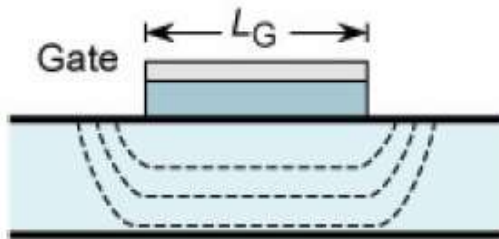

- Short-channel effects:
- Threshold-voltage shift
 - Lack of pinch-off
 - Increased leakage current
 - Increase of output conductance

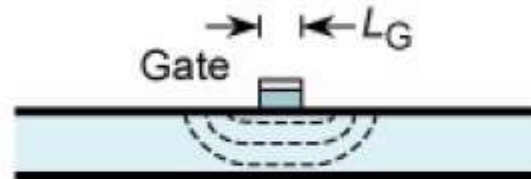
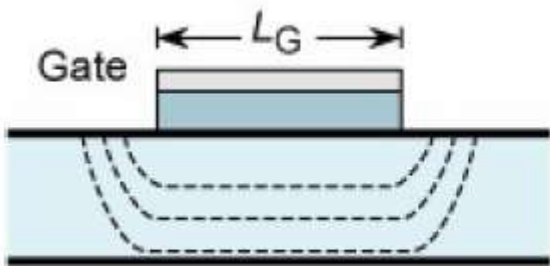

SOI: silicon on insulator

CMOS SOI

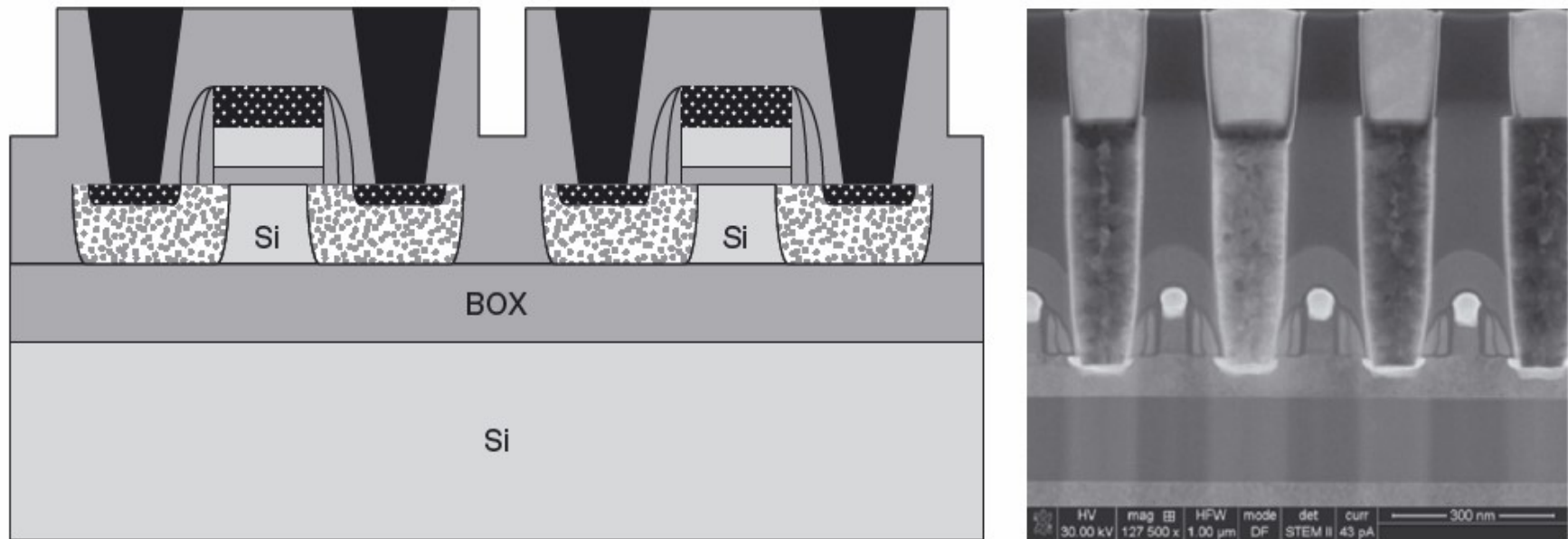
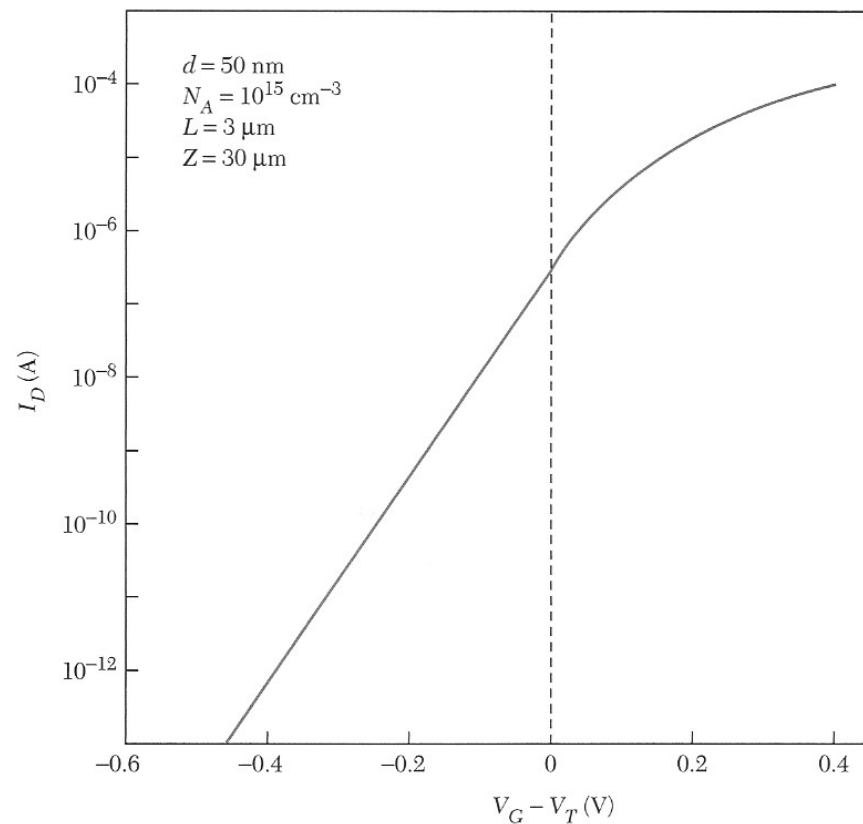

Figure 26.16 SOI MOSFET with first-level metal, schematic and TEM. Courtesy Brandon Van Leer, FEI Company⁴

Fransila

Subthreshold current

For $V_G < V_T$ the transistor should switch off but there is a diffusion current. The current is not really off until ~ 0.5 V below the threshold voltage.



Weak inversion

$$I_D \propto \exp\left(\frac{e(V_G - V_T)}{k_B T}\right)$$

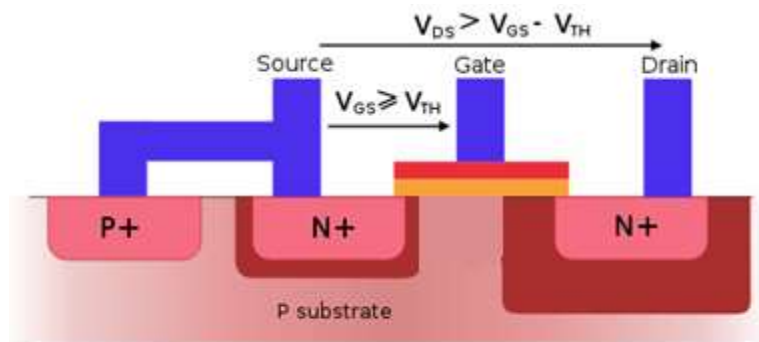

Subthreshold swing: 70-100 mV/decade

Subthreshold current

$$x_p = -\frac{\epsilon_s}{\epsilon_{ox}} t_{ox} + \sqrt{\left(\frac{\epsilon_s}{\epsilon_{ox}} t_{ox}\right)^2 + \frac{2\epsilon_s}{eN_A} (V_g - V_{fb})}$$

$$I_D \approx \frac{k_B T \mu W n_{2d}}{L} = \frac{n_i^2 \mu \epsilon_s k_B^2 T^2 W}{e^2 N_A^2 x_p L} \exp\left(\frac{e^2 N_A x_p^2}{2\epsilon_s k_B T}\right)$$

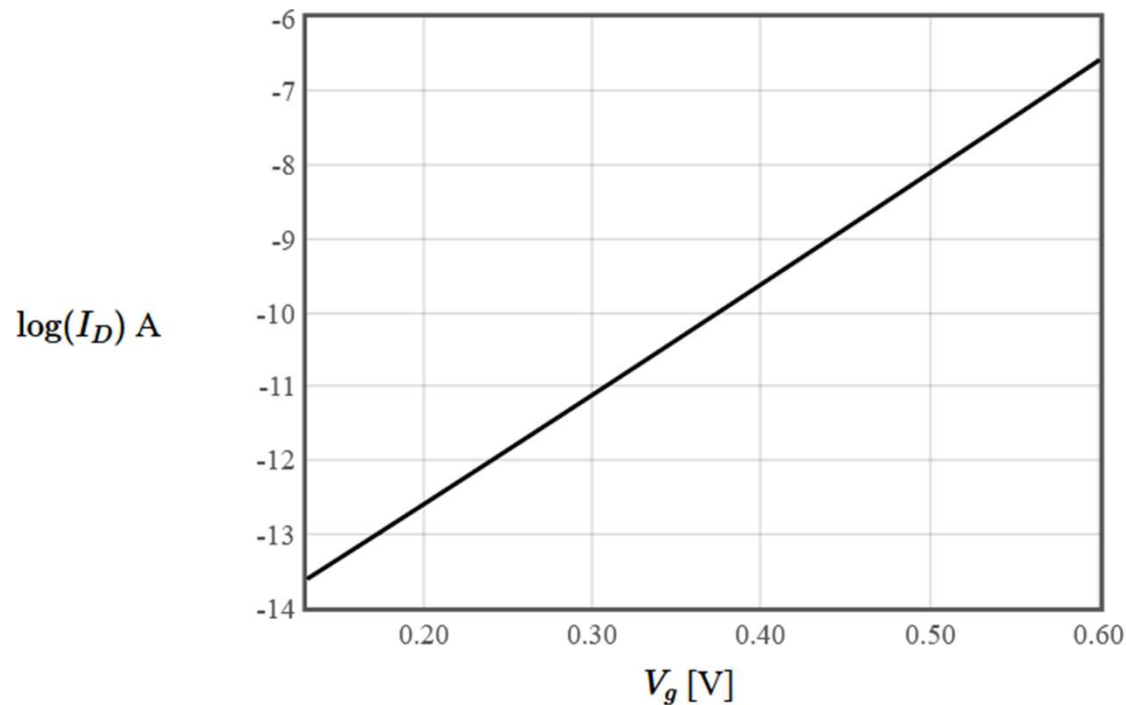

Subthreshold slope: 66 mV/decade

Memories

SRAM

Static random access memory

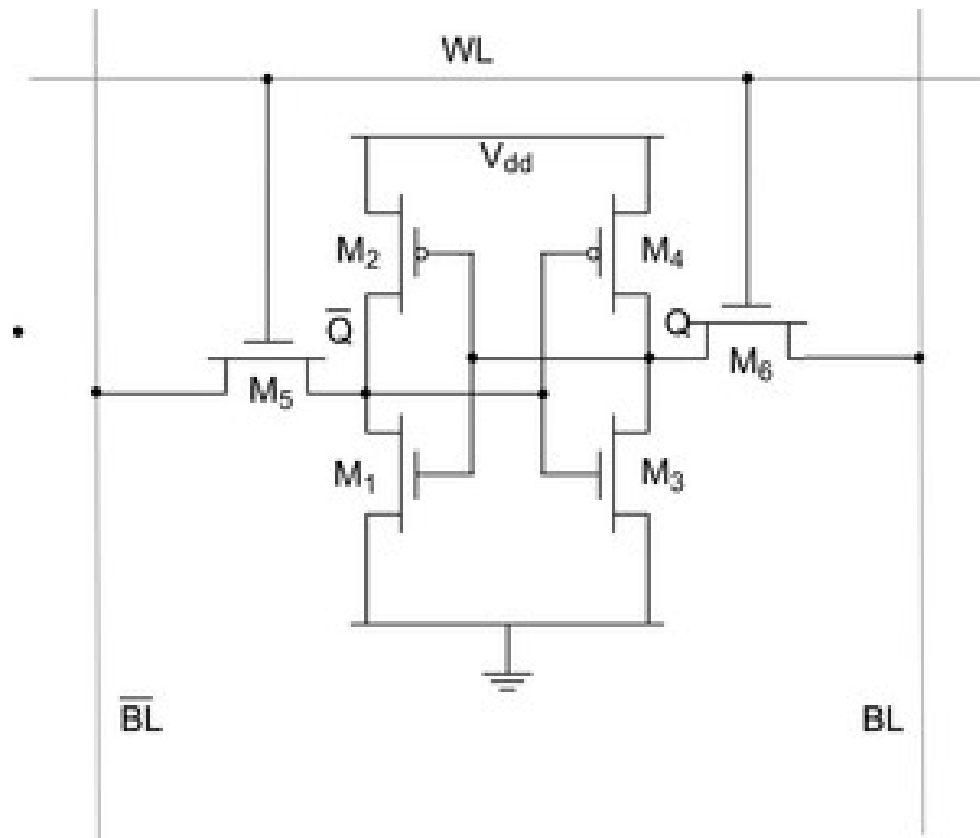
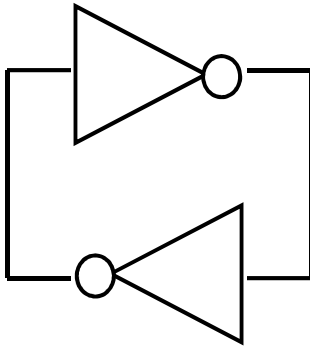

DRAM

Dynamic random access memory

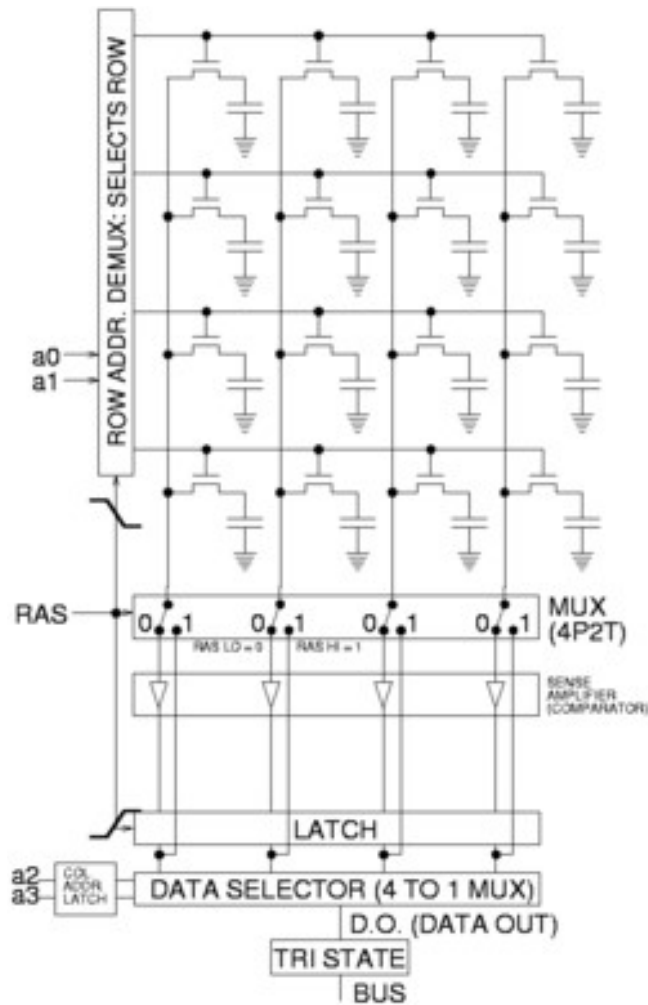

DRAM

Read and refresh DRAM with a SRAM cell

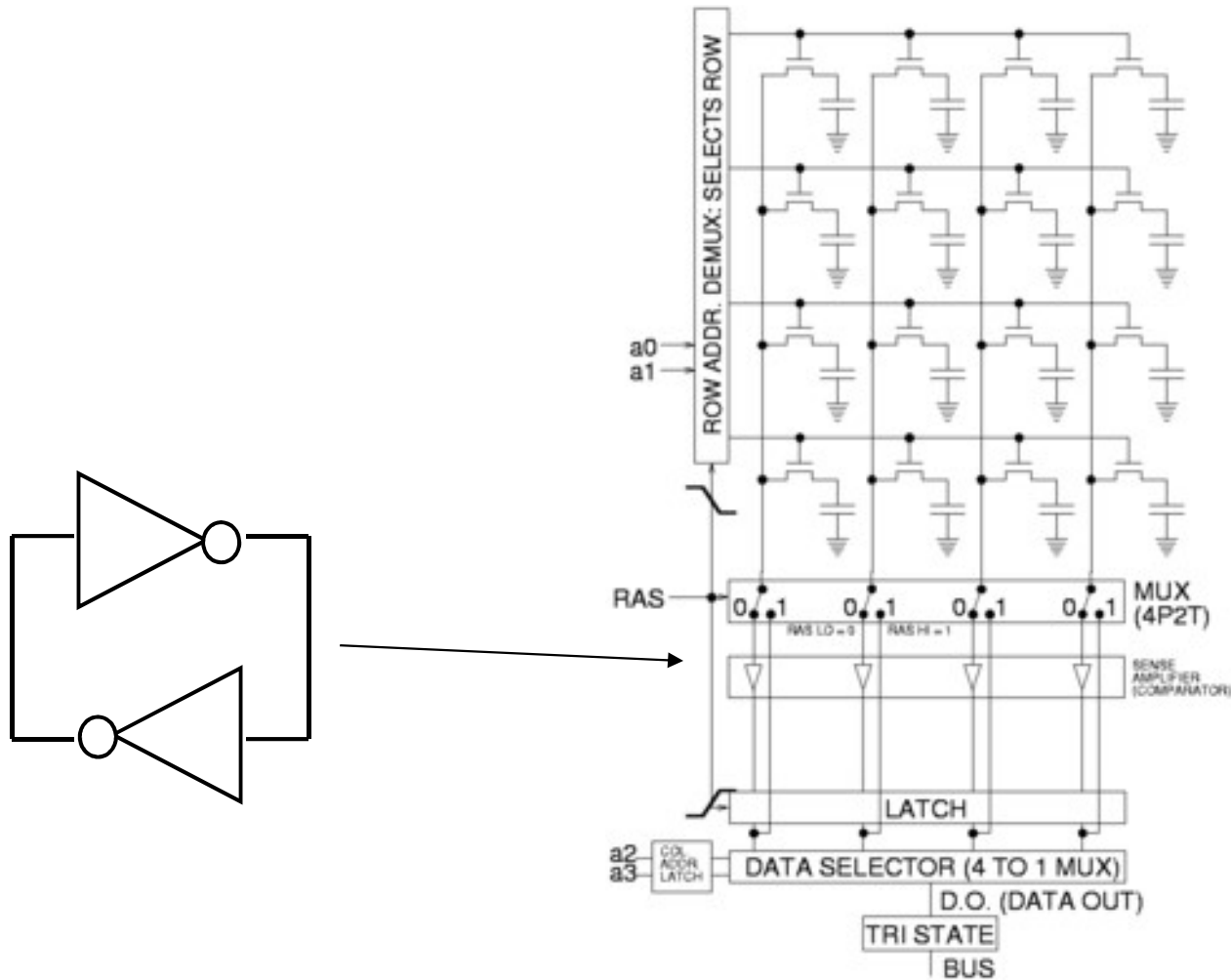

DRAM

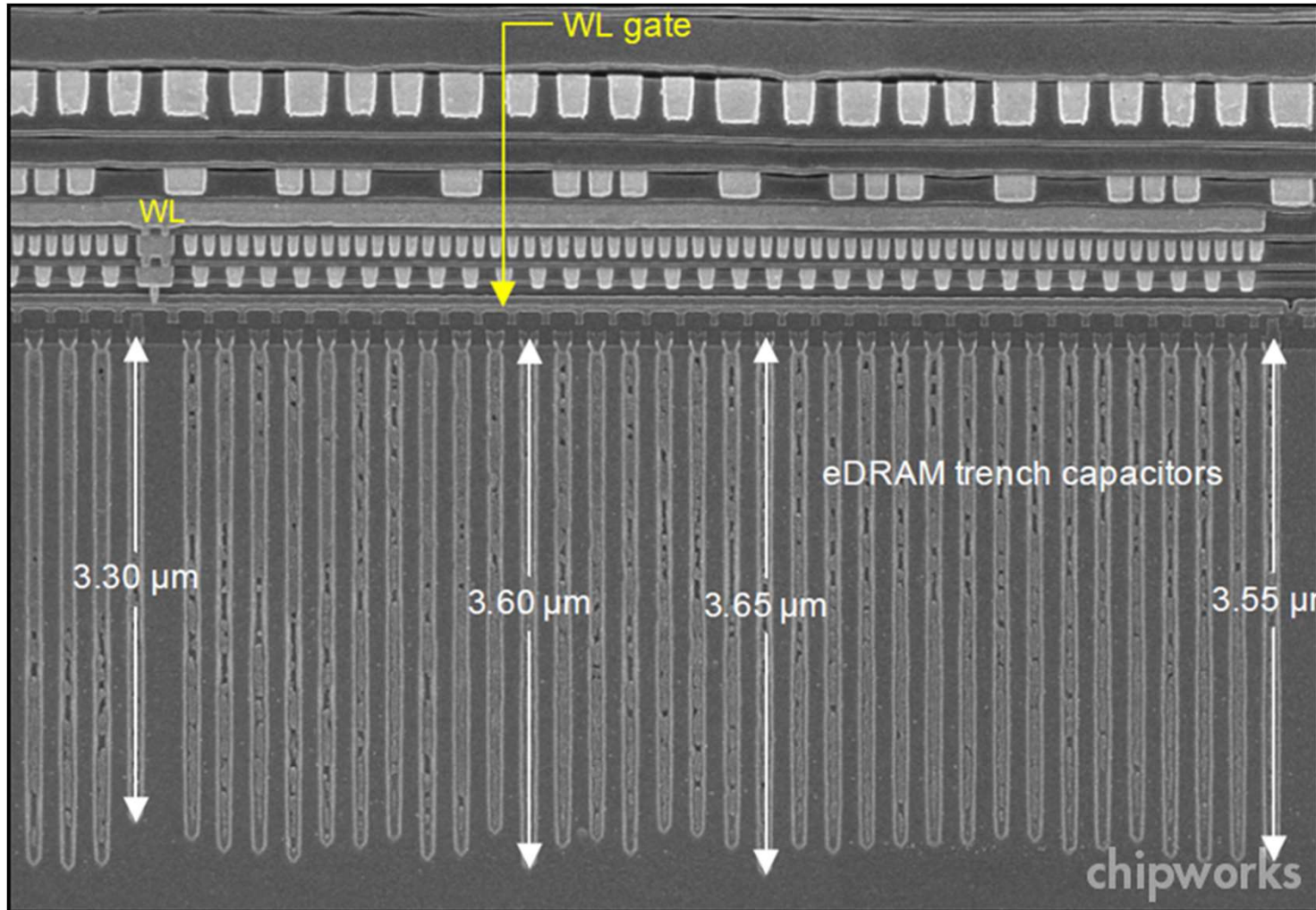

75:1

Silicon oxynitride SiO_xN_y dielectric

http://electroiq.com/chipworks_real_chips_blog/

Flash memory

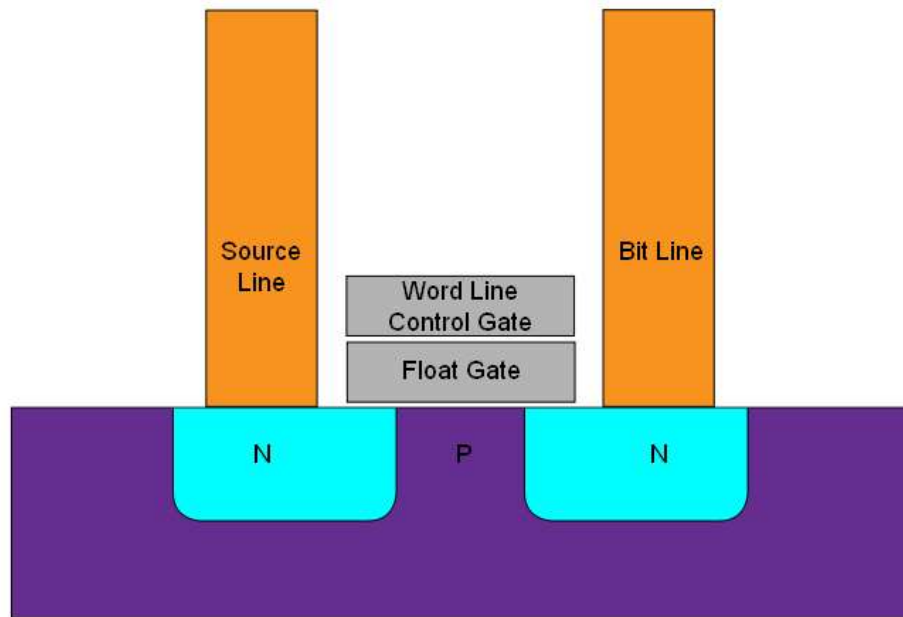

Charge is stored on a floating gate

nonvolatile