

NOTICE: This document contains references to Varian. Please note that Varian, Inc. is now part of Agilent Technologies. For more information, go to www.agilent.com/chem.



SH-110 ***Dry Scroll*** ***Vacuum Pump***

INSTRUCTION MANUAL

MANUALE DI ISTRUZIONI

NOTICE DE MODE D'EMPLOI

BEDIENUNGSHANDBUCH

使用手冊

使用說明書

사용 설명서

Manual No. 699904311
Revision A
July 2005

SH-110 Dry Scroll Vacuum Pump



Slo-Blo and Littelfuse are registered trademarks of Littelfuse, Inc.

Copyright 2005
Vacuum Technologies

Declaration of Conformity
Konformitätserklärung
Déclaration de Conformité
Declaración de Conformidad
Verklaring de Overeenstemming
Dichiarazione di Conformità
一致性声明
適合宣言
적합성 선언



We
Wir
Nous
Nosotros
Wij
Noi
我们
私たち
우리는

Varian, Inc.
Vacuum Technologies
121 Hartwell Avenue
Lexington, MA, 02421-3133 USA

declare under our sole responsibility that the product,
erklären, in alleniniger Verantwortung, daß dieses Produkt,
déclarons sous notre seule responsabilité que le produit,
declaramos, bajo nuestra sola responsabilidad, que el producto,
verklaren onder onze verantwoordelijkheid, dat het product,
dichiariamo sotto nostra unica responsabilità, che il prodotto,
基于独立承担责任的原则, 特声明
は、当社単独の責任の下、この宣言が該当する製品
당사의 책임하에

SH-110 Vacuum Pump

to which this declaration relates is in conformity with the following standard(s) or other normative documents.
auf das sich diese Erklärung bezieht, mit der/den flogenden Norm(en) oder Richtlinie(n) übereinstimmt.
auquel se réfère cette déclaration est conforme à la (aux) norme(s) ou au(x) document(s) normatif(s).
al que se refiere esta declaración es conforme a la(s) norma(s) u otro(s) documento(s) normativo(s).
waamaar deze verklaring verwijst, aan de volende norm(en) of richtlijn(en) beantwoordt.
a cui se riferisce questa dichiarazione è conforme alla/e sequente/l norma/o documento/l normativo/i.
符合以下标准或其它标准文档要求。
が、以下の規格またはその他の基準書類に適合することを宣言します。
이 선언과 관련한 제품이 다음의 표준과 기타 표준 문서를 준수한다는 것을 선언합니다.

98/37/EC Machine Directive
EN 61010-1
EN 60204-1 Safety of Machinery/Electrical Equipment of Machine
EN 292-1
EN 292-2
EN 1012-2
89/336/EC and 91/263/EC EMC Directive
EN55022
EN61000-4-3
EN61000-4-4
EN61000-4-2
EN61000-4-6
EN61000-4-5
EN61000-3-2
EN61000-3-3
EN61000-4-11

Frederick C. Campbell
Operations Manager
Vacuum Technologies
Varian, Inc.
Lexington, Massachusetts, USA
March 2001

Warranty

Products manufactured by Seller are warranted against defects in materials and workmanship for twelve (12) months from date of shipment thereof to Customer, and Seller's liability under valid warranty claims is limited, at the option of Seller, to repair, to replace, or refund of an equitable portion of the purchase price of the Product. Items expendable in normal use are not covered by this warranty. All warranty replacement or repair of parts shall be limited to equipment malfunctions which, in the sole opinion of Seller, are due or traceable to defects in original materials or workmanship. All obligations of Seller under this warranty shall cease in the event of abuse, accident, alteration, misuse, or neglect of the equipment. In-warranty repaired or replaced parts are warranted only for the remaining unexpired portion of the original warranty period applicable to the repaired or replaced parts. After expiration of the applicable warranty period, Customer shall be charged at the then current prices for parts, labor, and transportation.

Reasonable care must be used to avoid hazards. Seller expressly disclaims responsibility for loss or damage caused by use of its Products other than in accordance with proper operating procedures.

Except as stated herein, Seller makes no warranty, expressed or implied (either in fact or by operation of law), statutory or otherwise; and, except as stated herein, Seller shall have no liability under any warranty, expressed or implied (either in fact or by operation of law), statutory or otherwise. Statements made by any person, including representatives of Seller, which are inconsistent or in conflict with the terms of this warranty shall not be binding upon Seller unless reduced to writing and approved by an officer of Seller.

Warranty Replacement and Adjustment

All claims under warranty must be made promptly after occurrence of circumstances giving rise thereto, and must be received within the applicable warranty period by Seller or its authorized representative. Such claims should include the Product serial number, the date of shipment, and a full description of the circumstances giving rise to the claim. Before any Products are returned for repair and/or adjustment, written authorization from Seller or its authorized representative for the return and instructions as to how and where these Products should be returned must be obtained. Any Product returned to Seller for examination shall be prepaid via the means of transportation indicated as acceptable by Seller. Seller reserves the right to reject any warranty claim not promptly reported and any warranty claim on any item that has been altered or has been returned by non-acceptable means of transportation. When any Product is returned for examination and inspection, or for any other reason, Customer shall be responsible for all damage resulting from improper packing or handling, and for loss in transit, notwithstanding any defect or non-conformity in the Product. In all cases, Seller has the sole responsibility for determining the cause and nature of failure, and Seller's determination with regard thereto shall be final.

If it is found that Seller's Product has been returned without cause and is still serviceable, Customer will be notified and the Product returned at the Customer's expense; in addition, a charge for testing and examination may be made on Products so returned.

3/1/00

Contents

Declaration of Conformity	
Warranty	iv
Warranty Replacement and Adjustment	iv
Instructions for Use	1
General Information	1
Storage	1
Installation	2
Use	2
Maintenance	2
Istruzioni Per L'uso	3
Informazioni Generali	3
Immagazzinamento	3
Installazione	4
Uso	4
Manutenzione	4
Instructions D'utilisation	5
Indications Générales	5
Emmagasinage	5
Installation	6
Utilisation	6
Maintenance	6
Gebrauchsanleitung	7
Allgemeine Hinweise	7
Lagerung	7
Installation	8
Gebrauch	8
Wartung	8
使用说明	9
一般信息	9
贮存	9
安装	10
使用	10
维护与维修	10
はじめに	11
一般情報	11
保管	11
設置	12
使用	12
保守	12
사용 지침	13
일반 정보	13
보관	13
설치	14
사용	14
유지 보수	14

Technical Information	15
Unpacking and Inspection	17
Installation	18
Safety	18
Startup	18
Electrical Connections	18
Run Currents	20
Start Current	20
Mechanical Connections	21
Operation	21
Cleaning the Pump	21
Startup Procedure	21
Shutdown Procedure	21
Troubleshooting	22
Maintenance	23
Kits and Service Options	23
Cleaning	23
Tip Seal Replacement	23

Request for Return Health and Safety Certification

List of Figures

Figure	Caption	Page
1	Interface Drawing with Dimensions	16
2	Pumping Speed Curves	16
3	Outline Drawing and Principal Items	17
4	Grounding Plug and Outlet	20
5	ON/OFF Power Switch	21
6	Exploded View of Pump Body	24

List of Tables

Table	Title	Page
1	Specifications	15
2	SH-110 Power Cord Selection	19
3	SH-110 Typical Run Currents	20
4	Typical SH-110 Maximum Starting Current and Duration @ 115 V	20
5	Troubleshooting Chart	22
6	Tip Seal Replacement Kit	23
7	Factory Service Options	23

SH-110 Dry Scroll Vacuum Pump

This page intentionally left blank.

Instructions for Use

General Information

This equipment is designed for use by professionals. The user should read this instruction manual and any other additional information supplied by Vacuum Technologies before operating the equipment. Vacuum Technologies will not be held responsible for any events that occur due to non-compliance with these instructions, improper use by untrained persons, non-authorized interference with the equipment, or any action contrary to that provided for by specific national standards.

The SH-110 is a hermetic, dry scroll vacuum pump. This pump is suitable for pumping air or inert gases. The pump is not intended to pump corrosive, explosive, or particulate-forming gases.

The following paragraphs contain all the information necessary to guarantee the safety of the operator when using the equipment. Detailed information is supplied in "Technical Information" on page 15.

This manual uses the following standard safety protocol:

WARNING



The warning messages are for attracting the attention of the operator to a particular procedure or practice which, if not followed correctly, could lead to serious injury.

CAUTION



The caution messages are displayed before procedures, which if not followed, could cause damage to the equipment.

NOTE



The notes contain important information taken from the text.

Storage

When transporting and storing the pump, the following environmental requirements should not be exceeded:

Temperature: $-20\text{ }^{\circ}\text{C}$ to $+60\text{ }^{\circ}\text{C}$ ($-4\text{ }^{\circ}\text{F}$ to $140\text{ }^{\circ}\text{F}$)

Relative humidity: 0 to 95% (non-condensing)

Preparation for Installation

The pump is supplied in a special protective packing. If this shows signs of damage, which may have occurred during transport, contact your local sales office.

Total weight of the packing, SH-110 pump included, is approximately 20 kg (44 lbs).

WARNING



When unpacking the pump, be sure not to drop it and avoid any kind of sudden impact or shock vibration to it.

NOTE



Normal exposure to the environment cannot damage the pump. Nevertheless, it is advisable to keep the pump inlet closed until the pump is installed in the system.

SH-110 Dry Scroll Vacuum Pump

Installation

Do not install or use the pump in an environment exposed to atmospheric agents (rain, snow, ice), dust, aggressive gases, or in explosive environments or those with a high fire risk.

If placing the SH-110 pump inside an enclosure, provide ample room to supply ambient air to both the front and rear air intakes of the pump.

During operation, the following environmental conditions must be respected:

Temperature: +5 °C to +40 °C (41 °F to 104 °F)

Relative humidity: 0 to 95% (non-condensing)

CAUTION



Be certain that your electrical mains power voltage corresponds to that indicated on the white tab (110 or 220) adjacent to the On/Off switch on the rear of the pump.

If voltage changeover is required, use a small screwdriver to remove the tab holder from the power module. Position the white tab so that the correct voltage faces out and reinstall the tab holder.

Connect the pump to the power supply using an IEC-320 style power cord of at least 10 A capacity.

Use

In order to reach maximum vacuum, the pump must be left running for about an hour with the inlet sealed.

There are no special instructions for starting the pump; it need only be switched on using the On/Off switch.

The inlet valve will open 10 seconds after the pump is started.

WARNING



The pump is designed for operation with neutral or noncorrosive fluids. It is absolutely forbidden to use it with potentially explosive or inflammable substances.

There are no special instructions for stopping the pump; it need only be disconnected from the electric power source by the On/Off switch.

The inlet valve will close immediately after the pump is stopped.

Maintenance

Personnel responsible for pump operation and maintenance must be well-trained and aware of the accident prevention rules.

WARNING



- Death may result from contact with high voltages. Always take extreme care and observe the accident prevention regulations in force.*
- When machine is powered up, be careful of moving parts and high voltages.*
- If you have to perform maintenance on the pump after a considerable time in operation, allow it to cool as the temperature of the outer surface may be in excess of 60 °C.*
- Always disconnect your power supply to the pump before beginning maintenance work.*

NOTE



Before returning the pump to the factory for repair, the "Health and Safety" sheet attached to this instruction manual must be completed and sent to the local sales office. A copy of the sheet must be inserted in the pump package before shipping.

If a pump is to be discarded, it must be disposed of in accordance with specific national standards.

Istruzioni Per L'uso

Informazioni Generali

Questa apparecchiatura è destinata ad uso professionale. L'utilizzatore deve leggere attentamente il presente manuale di istruzioni ed ogni altra informazione addizionale fornita dalla Vacuum Technologies prima dell'utilizzo dell'apparecchiatura. La Vacuum Technologies si ritiene sollevata da eventuali responsabilità dovute all'inosservanza totale o parziale delle istruzioni, ad uso improprio da parte di personale non addestrato, ad interventi non autorizzati o ad uso contrario alle normative nazionali specifiche.

La pompa a secco Scroll SH-110 è una pompa ermetica adatta a pompare aria or gas inerti.

Questa pompa non è adatta per pompare gas or particelle tossiche, corrosive or esplosive.

Nei paragrafi seguenti sono riportate tutte le informazioni necessarie a garantire la sicurezza dell'operatore durante l'utilizzo dell'apparecchiatura. Per informazioni dettagliate, vedere "Technical Information" a pagina 15.

Questo manuale utilizza le seguenti convenzioni:

PERICOLO



I messaggi di pericolo attirano l'attenzione dell'operatore su una procedura o una pratica specifica che, se non eseguita in modo corretto, potrebbe provocare gravi lesioni personali.

ATTENZIONE



I messaggi di attenzione sono visualizzati prima di procedure che, se non osservate, potrebbero causare danni all'apparecchiatura.

NOTA



Le note contengono informazioni importanti estrapolate dal testo.

Immagazzinamento

Durante il trasporto e l'immagazzinamento della pompa non devono essere superate le seguenti condizioni ambientali:

Temperatura: $-20\text{ }^{\circ}\text{C}$ a $+60\text{ }^{\circ}\text{C}$

Umidità relativa: 0 a 95% (non condensante)

Preparazione Per L'installazione

La pompa viene fornita in un imballo protettivo speciale; se si presentano segni di danni, che potrebbero essersi verificati durante il trasporto, contattare l'ufficio vendite locale.

Il peso dell'imballo, comprensivo della pompa SH-110, è di circa 20 kg.

PERICOLO



Durante l'operazione di disimballaggio, prestare particolare attenzione a non lasciar cadere la pompa e a non sottoporla ad urti o vibrazioni.

NOTA



La pompa non può essere danneggiata rimanendo semplicemente esposta all'atmosfera. Si consiglia comunque di mantenerla chiusa fino al momento dell'installazione sul sistema onde evitare eventuale inquinamento da polvere.

Installazione

Non installare e/o utilizzare la pompa in ambienti esposti ad agenti atmosferici (pioggia, gelo, neve), polveri, gas aggressivi, in ambienti esplosivi o con elevato rischio di incendio.

Durante il funzionamento è necessario che siano rispettate le seguenti condizioni ambientali:

Temperatura: +5 °C a +40 °C
Umidità relativa: 0 a 95% (non condensante)

ATTENZIONE



Verificate che la tensione di rete corrisponda ai valori indicati sulla etichetta bianca (110 or 220) adiacente all'interruttore On/Off sul retro della pompa. Se il cambiamento di tensione è richiesto, utilizzate un piccolo cacciavite per togliere la linguetta bianca dal modulo di potenza. Posizionate la linguetta bianca in corrispondenza al voltaggio di rete e riinstallate il tutto.

Collegare la pompa alla rete utilizzando un cavo da 10 A con presa IEC-320.

Uso

Prima di mettere la pompa in servizio effettivo è necessario, per il raggiungimento del vuoto limite, scaldare la pompa per circa 60 minuti lasciandola lavorare con la flangia di ingresso chiusa.

Non ci sono particolari istruzioni per far partire la pompa; basta accenderla utilizzando l'interruttore On/Off.

La valvola di ingresso si apre 10 secondi dopo la partenza della pompa.

PERICOLO



La pompa è progettata per operare con fluidi neutri o non corrosivi. E' assolutamente vietato l'impiego con sostanze potenzialmente esplosive, infiammabili o velenose.

Lo spegnimento della pompa non richiede particolari manovre; è sufficiente scollegarla dall'alimentazione elettrica agendo sull'apposito interruttore.

NOTA



La valvola di ingresso si chiude immediatamente quando si spegne la pompa.

Manutenzione

Il personale addetto alla condotta ed alla manutenzione della pompa deve essere ben addestrato e deve avere una approfondita conoscenza delle norme antinfortunistiche.

PERICOLO



- ❑ Le alte tensioni possono causare morte al contatto. Operare sempre con la massima cautela e secondo le norme antinfortunistiche in vigore.
- ❑ Quando la macchina è alimentata prestare attenzione per la presenza di parti in movimento e di alta tensione.
- ❑ Nel caso si debba procedere ad operazioni di manutenzione della pompa al termine di un periodo di esercizio, è necessario lasciarla raffreddare, poiché la temperatura esterna può superare i 60 °C.
- ❑ Escludere sempre l'alimentazione della pompa prima di compiere operazioni di manutenzione.

NOTA



Prima di rispedire al costruttore una pompa per riparazioni, è indispensabile compilare e far pervenire al locale ufficio vendite la scheda "Sicurezza e Salute" allegata al presente manuale di istruzioni. Copia della stessa deve essere inserita nell'imballo della pompa prima della spedizione.

Qualora una pompa dovesse essere rottamata, procedere alla sua eliminazione nel rispetto delle normative nazionali specifiche.

Instructions D'utilisation

Indications Générales

Cet appareillage a été conçu en vue d'une utilisation professionnelle. Il est conseillé à l'utilisateur de lire attentivement cette notice d'instructions ainsi que toute autre indication fournie par Vacuum Technologies avant d'utiliser l'appareil. Vacuum Technologies décline par conséquent toute responsabilité en cas de non-respect total ou partiel des instructions fournies, d'utilisation incorrecte de la part d'un personnel non formé, d'opérations non autorisées ou d'un emploi contraire aux réglementations nationales spécifiques.

La pompe SH-110, est une pompe à vide sèche et hermétique. Cette pompe convient pour le pompage de l'air ou de gaz inertes. Elle n'a pas été conçue pour le pompage de gaz toxiques, corrosifs, explosifs, ou susceptibles de générer des particules.

Les paragraphes suivants fournissent toutes les indications nécessaires pour garantir la sécurité de l'opérateur pendant l'utilisation de l'appareillage. Les détails sont fournis en page 15 dans le paragraphe "Technical Information".

Cette notice utilise les signes conventionnels suivants:

DANGER



Les messages de danger attirent l'attention de l'opérateur sur une procédure ou une manœuvre spéciale dont la mauvaise exécution risque de provoquer de graves lésions au personnel.

ATTENTION



Les messages d'attention apparaissent avant certaines procédures dont le non-respect peut endommager sérieusement l'appareillage.

NOTENT



Les notes contiennent des renseignements importants, extrapolés du texte.

Emmagasinage

Pendant le transport et l'emmagasinage de la pompe, il faut veiller à respecter les conditions environnementales suivantes:

Température: -20 °C à +60 °C

Humidité relative: 0 à 95% (non condensante)

Préparation Pour L'installation

La pompe est fournie dans un emballage de protection spécial; si l'on constate des marques de dommages pouvant s'être produits pendant le transport, contacter aussitôt le bureau de vente local.

Le poids total de l'emballage et de la pompe SH-110 est d'environ 20 kg.

DANGER



Pendant l'opération d'ouverture de l'emballage, veiller tout particulièrement à ne pas laisser tomber la pompe et à ne lui faire subir aucun choc ni aucune vibration.

NOTENT



La pompe ne peut être endommagée en restant simplement exposée à l'atmosphère. Il est de toute façon conseillé de la garder dans son emballage jusqu'au moment de sa mise en fonction afin d'éviter toute pollution due à la poussière

SH-110 Dry Scroll Vacuum Pump

Installation

Ne pas installer et/ou utiliser la pompe dans des milieux exposés aux agents atmosphériques (pluie, gel, neige), à des poussières, à des gaz agressifs ainsi que dans des milieux explosifs ou à fort risque élevé d'incendie.

Pendant le fonctionnement, il est nécessaire de respecter les conditions environnementales suivantes:

Température: +5 °C à +40 °C
Humidité relative: 0 à 95% (non condensante)

ATTENTION



S'assurer que la tension fournie par votre générateur corresponde à celle indiquée sur l'étiquette blanche (110 ou 220) adjacente au bouton On/Off au rétro de la pompe. Pour changer la tension de travail, utilisez un petit tourne-vis pour retirer la protection de l'étiquette du module de tension. Positionner l'étiquette blanche en face de la tension désirée et remettre la protection.

Connecter la pompe au générateur de tension par le biais d'un cordon d'alimentation IEC-320 d'une capacité minimale de 10 ampères.

Utilisation

Avant la mise en service de la pompe, il est nécessaire, pour atteindre le vide maximum, que la pompe tourne environ une heure avec l'entrée hermétiquement fermée.

Il n'y a pas d'instructions spéciales pour démarrer la pompe; la mise en marche se fait à l'aide du commutateur On/Off.

La valve d'entrée s'ouvre 10 secondes après la mise en marche de la pompe.

DANGER



La pompe a été conçue pour fonctionner avec des fluides neutres ou non corrosifs. L'emploi de substances potentiellement explosives, inflammables ou vénéneuses est strictement interdit.

L'arrêt de la pompe ne requiert aucune manœuvre particulière; il faut seulement la déconnecter de l'alimentation électrique grâce au bouton On/Off.

NOTENT



La valve d'entrée se ferme immédiatement à l'arrêt de la pompe.

Maintenance

Le personnel chargé de la conduite et de la maintenance de la pompe doit avoir reçu la formation nécessaire et posséder une connaissance approfondie des normes de prévention des accidents du travail.

DANGER



Les hautes tensions peuvent entraîner la mort par contact. Veiller à toujours opérer avec le maximum de prudence et dans le respect des normes de prévention des accidents du travail en vigueur.

Lorsque la machine est sous alimentation, faire attention à la présence d'organes en mouvement et de haute tension.

En cas de nécessité de procéder à des opérations de maintenance de la pompe au terme d'une période de fonctionnement, il est indispensable de la laisser refroidir car sa température extérieure peut être supérieure à 60 °C.

Avant toute opération de maintenance, il est impératif de toujours couper l'alimentation de la pompe.

NOTENT



Avant de retourner une pompe au constructeur pour réparation, il est indispensable de remplir et d'adresser au bureau local de vente la fiche "Sécurité et Santé" jointe à la présente notice d'instructions. Une copie de celle-ci devra être mise dans l'emballage de la pompe avant expédition.

En cas de mise au rebut de la pompe, procéder à son élimination conformément aux réglementations nationales en la matière.

Gebrauchsanleitung

Allgemeine Hinweise

Dieses Gerät ist für den professionellen Gebrauch bestimmt. Vor dem Gebrauch soll der Benutzer dieses Handbuch sowie alle weiteren von Vacuum Technologies mitgelieferten Zusatzinformationen genau lesen. Bei vollständiger bzw. teilweiser Nichtbeachtung der enthaltenen Hinweise, unsachgemäßem Gebrauch durch ungeschultes Personal, nicht autorisierten Eingriffen und Benutzung unter Mißachtung der nationalen Bestimmungen übernimmt Firma Vacuum Technologies keinerlei Haftung.

Die Pumpe SH-110 ist eine hermetisch dichte trockenlaufende Vakuumpumpe (Scrollpumpe).

Diese Vorvakuumpumpe eignet sich für das Pumpen von Luft oder inerten Gasen. Die Pumpe ist nicht zum Abpumpen von toxischen, korrosiven oder explosiven Gasen geeignet. Ferner sind Partikel zu vermeiden.

In den folgenden Abschnitten sind alle erforderlichen Informationen für die Sicherheit des Bedieners bei der Verwendung des Geräts aufgeführt. Nähere Einzelheiten sind den "Technical Information" auf Seite 15 zu entnehmen.

In dieser Gebrauchsanleitung werden Sicherheitshinweise folgendermaßen hervorgehoben:

GEFAHR



Die Gefahrenhinweise richten die Aufmerksamkeit des Bedieners auf eine spezielle Prozedur oder Praktik, die bei unkorrekter Ausführung schwere Personenschäden zur Folge haben könnte.

ACHTUNG



Die Warnhinweise vor bestimmten Prozeduren machen den Bediener darauf aufmerksam, daß bei Nichteinhaltung Schäden am Gerät entstehen können.

ANMERKUNG



Die Anmerkungen enthalten wichtige Informationen, die aus dem Text hervorgehoben werden.

Lagerung

Während des Transports und der Lagerung der Pumpe sollen die folgenden Umgebungsbedingungen gegeben sein:

Temperatur: -20 °C bis $+60\text{ °C}$

Relative Feuchtigkeit: 0 bis 95% (niederschlagsfrei)

Vor Der Installation

Die Pumpe wird in einer speziellen Schutzverpackung geliefert. Eventuelle Transportschäden sind der zuständigen örtlichen Verkaufsstelle zu melden.

Das Verpackungsgewicht beträgt, einschließlich der Pumpe SH-110, ungefähr 20 kg.

GEFAHR



Beim Auspacken ist darauf zu achten, daß die Pumpe nicht fallengelassen oder Stößen oder Vibrationen ausgesetzt wird.

ANMERKUNG



Die Pumpe kann, wenn sie einfach der Atmosphäre ausgesetzt ist, nicht beschädigt werden. Sie sollte jedoch bis zur Installation an der Anlage geschlossen bleiben, um Verunreinigungen durch Staub zu vermeiden.

SH-110 Dry Scroll Vacuum Pump

Installation

Die Pumpe darf nicht in Umgebungen installiert und/oder benutzt werden, die ungeschützt vor Witterungsbedingungen (Regen, Frost, Schnee), Staub und aggressiven Gasen sind und in denen Explosions oder erhöhte Brandgefahr besteht.

Während des Betriebs sollen die folgenden Umgebungsbedingungen gegeben sein:

Temperatur: +5 °C bis +40 °C
Relative Feuchtigkeit 0 bis 95% (niederschlagsfrei)

ACHTUNG



Stellen Sie sicher, daß die Betriebsspannung mit der auf dem weißen Schild (110 oder 220) neben dem Einschalter On/Off auf der Rückseite der Pumpe übereinstimmt.

Falls ein Wechsel der Spannung erforderlich wird, nehmen Sie einen kleinen Schraubendreher um das Abdeckschild zu entfernen. Drehen Sie nun den Spannungselektor auf die gewünschte Spannung und schließen das Abdeckschild. Sie sehen jetzt auf einem weißen Hintergrund die von Ihnen gewählte Spannung.

Schließen Sie die Pumpe über ein Netzkabel (IEC-320 Typ) für mindestens 10 A an.

Gebrauch

Vor der eigentlichen Inbetriebnahme der Pumpe ist es zur Erreichung des Grenzvakuums erforderlich, die Pumpe ungefähr eine Stunde laufen zu lassen.

Die Einschaltung der Pumpe erfordert keine speziellen Schritte, es ist lediglich der Schalter On/Off zu betätigen.

Das Einlaßventil wird ca. 10 sec. Nach Einschalten der Pumpe öffnen.

GEFAHR



Die Pumpe ist für den Betrieb mit neutralen und nicht korrosiven Fluiden konzipiert. Der Einsatz mit potentiell explosions- oder feuergefährlichen oder giftigen Substanzen ist streng verboten.

Das Ausschalten der Pumpe erfordert keine speziellen Schritte, sie braucht nur durch Betätigung des Schalters On/Off abgeschaltet werden.

ANMERKUNG



Das Einlaßventil schließt unverzüglich nach Abschalten der Pumpe.

Wartung

Das für den Betrieb und die Wartung zuständige Personal soll geschult sein und über eine solide Kenntnis der Unfallschutzvorschriften verfügen.

GEFAHR



Hochspannungen können bei Kontakt tödliche Folgen haben. Es ist stets mit größter Vorsicht und gemäß der geltenden Unfallschutzvorschriften vorzugehen.

Bei eingeschaltetem Gerät ist auf Bewegungs- und Hochspannungsteile zu achten.

Falls die Pumpe im Anschluß an den Betrieb gewartet werden soll, ist abzuwarten, bis sie abgekühlt ist, da ihre Oberfläche eine Temperatur von 60 °C überschreiten kann.

Vor Wartungsarbeiten ist die Pumpe stets energiefrei zu schalten.

ANMERKUNG



Bevor dem Hersteller eine Pumpe zur Reparatur zurückgesandt wird, ist das Formular "Sicherheit und Gesundheit" in der Anlage zum vorliegenden Handbuch auszufüllen und der lokalen Verkaufsstelle zuzustellen. Eine Kopie des Formulars ist der Pumpenverpackung vor dem Versand beizulegen.

Bei eventueller Verschrottung einer Pumpe ist diese entsprechend der einschlägigen nationalen Vorschriften zu entsorgen.

使用说明

一般信息

本设备仅可由专业人员操作和使用。操作本设备之前，使用人员应认真阅读本使用手册及由 Vacuum Technologies 提供的其它所有相关说明。Vacuum Technologies 对于因未按使用手册指导进行违规操作、未经培训人员执行不当操作、未获授权的设备连接、或其它与特定国家标准及规章相违反的行为而引起的任何问题或事件，概不负责。

SH-110 为气密型干滚式真空泵。此泵可稳定地泵吸空气或惰性气体。此泵并非设计用于泵吸有毒、腐蚀性、爆炸性或含有细微颗粒的气体。

以下说明旨在提供使用本设备时保障操作员安全需遵守的事项及有关信息。详情说明，请参阅第 15 页“技术信息”。

本手册使用以下标准安全警示标志：



警告

警告信息用于引起操作人员的注意力，使其注意某个特定步骤或如果操作不当便会导致严重人身伤害的操作。



注意

注意事项消息显示在操作步骤之前，必须遵守，否则会损坏设备。



注释

注释包含从正文摘录的重要信息。

贮存

当将泵运输到其它地方或进行贮存时，不应超出以下环境范围要求：

温度： -20 °C 至 +60 °C (-4 °F 至 140 °F)

相对湿度： 0 至 95% (无冷凝)

安装准备

本泵在发货时采用特殊的保护性包装。如果发现运输期间可能造成的包装受损迹象，请与当地销售办事处联系。

包装总重量，包括 SH-110 泵本身在内，约为 20 千克 (44 磅)。



警告

当拆开泵包装时请小心谨慎，避免将泵跌落，或对其造成较大撞击或振动。



注释

在正常环境中置放和使用，不会对泵造成任何损害。但建议您在将泵安装到系统之前，让泵的入口保持密闭。

安装

不要将泵安装在易受自然天气侵害 (如下雨、下雪、结冰) 的环境中, 不要在多尘、周围存在腐蚀性气体、易发生爆炸场所或易引起火灾的环境中使用本泵。

操作期间, 必须留意并符合以下环境条件。

温度: +5 °C 至 +40 °C (41 °F 至 104 °F)

相对湿度: 0 至 95% (无冷凝)

注意



检查并确保设备的供电电源电压与泵体背面电源开关旁边的调整片指示的电压一致(110V 或 220V)。

如果需要修改电压, 请使用小号螺丝刀拨开电源模块上的调整片护架。将白色调整片拨到指向正确的电压, 然后重新装回调整片护架。

使用额定电流至少为 10 A 的 IEC-320 型电源电缆, 将泵连接到主供电电源上。

使用

为确保达到最高真空度, 必须让泵在入口密封密闭的情况下运行至少约一小时。

启动泵并无特别要求; 只需使用 On/Off 开关将泵置于电源打开状态。

泵启动后, 入口阀将打开约 10 秒钟。

警告



此泵设计用于输送中性或非腐蚀性液体。严禁用此泵输送存在潜在爆炸、易燃或毒性危险的物质。

停止泵并无特别要求; 只需使用 On/Off 开关将泵置于断开电源的状态。

泵停止后, 入口阀将立即关闭。

维护与维修

负责操作和维护泵的人员, 必须接受良好的专业培训, 并熟知突发事件预防及处理规程。

警告



- ❑ 接触高电压将有导致死亡的危险。应始终保持格外小心, 并遵守预防突发事件的规章和要求。
- ❑ 机器处于开机运转状态时, 应特别留意避开移动部件和高压区。
- ❑ 如果在操作一定时间之后需要对泵进行维修检查, 应让泵先完全冷却, 因为操作期间泵体外表的温度可能超过 60 °C。
- ❑ 在开始维修之前, 必须先断开泵的电连接。

注释



在将泵退回工厂修理之前, 必须填写本手册中附带的“健康与安全证明”单, 并将其寄至当地销售办事处。退运产品进行包装时, 应将此证明单的一份副本放入泵的包装箱内。

如果需要将泵废弃并丢弃, 必须遵守本国的特定废品处理规章。

はじめに

一般情報

本装置は、専門家による使用を想定して設計されています。ユーザーは装置を使用する前に、本取扱説明書、および Varian Technologies が提供するその他の情報を読んでください。これらの説明書の指示を守らなかった場合や未熟練者による誤用、装置に対する未認可の干渉、または該当する国内基準に反する行動によって発生した事態に対し責任を負いません。

SH-110 は密封式ドライ スクロール真空ポンプです。このポンプは、エアまたは不活性ガスのポンピングに適しています。ポンプは、有害ガス、腐食性ガス、爆発性ガス、または粒子生成ガスには適していません。

下記には装置を使用するオペレータの安全を保障するための情報が記載されています。詳細情報は、15ページの“Technical Information”に記載されています。

本マニュアルは、以下の標準安全規約を採用しています。



警告文は、正しく守らなければ深刻なケガにつながる特定の手順や業務について、オペレーターに注意を促すためのものです。



注意文は、守らなければ装置への損傷につながるような手順の前に記載されています。



注記は、文章から選択された重要な情報を含んでいます。

保管

ポンプを輸送および保管する際は、以下の環境条件を守ってください。

温度: $-20^{\circ}\text{C} \sim +60^{\circ}\text{C}$ ($-4^{\circ}\text{F} \sim 140^{\circ}\text{F}$)

相対湿度: 0 ~ 95% (結露なきこと)

取付け準備

ポンプは特別な保護梱包材に入れられて供給されます。梱包材にキズや破れがある場合、輸送中に損傷したものであると思われるので、最寄の営業所にお問い合わせください。

SH-110 ポンプを含む荷物の総重量は約 20 kg です。



ポンプを開梱する際に落としたり、衝撃や振動を与えないようにしてください。



通常的环境下ではポンプは損傷することはありません。ただし、ポンプをシステムに設置するまでポンプの吸気口は閉じておくことをお勧めします。

設置

大気中の作用物 (雨、雪、氷)、ダスト、悪性ガスにさらされるような環境、爆発性雰囲気、または火災危険度の高い環境下でポンプを設置したり、使用したりしないでください。

動作時は以下の環境条件に準拠してください：

温度： +5 °C ~ +40 °C (41 °F ~ 104 °F)

相対湿度： 0 ~ 95% (結露なきこと)

注意



ご使用の主電力電圧が、ポンプ背面のオン/オフスイッチの隣にある白いタブに記載されている数値 (110 または 220) と一致していることを確認してください。

電圧変換が必要な場合、小型のドライバーでパワー モジュールのタブホルダを取り外します。正しい電圧値が外側から見えるように白いタブの位置を決め、タブホルダを元の位置に戻します。

容量が 10A 以上の IEC-320 型パワーコードを使用してポンプを電源に接続してください。

使用

最大真空圧に達するには、吸入口を閉じた状態でポンプを約 1 時間、回しておく必要があります。

ポンプを始動する上で特別な手順は要りません。オン/オフスイッチをオンにするだけです。

ポンプが始動してから約 10 秒後に吸入バルブが開きます。

警告



ポンプは中性、または非腐食性の液体を使用する目的で設計されています。潜在的に爆発性、可燃性、または毒性を有する物質へのご使用は厳禁です。

ポンプを停止する上で特別な手順は要りません。オン/オフスイッチにより電源から切り離すだけです。

ポンプが停止すると同時に吸入バルブが閉じます。

保守

ポンプの操作・保守責任者は、十分な訓練を受けており事故防止規則に精通している必要があります。

警告



- 高電圧に触れると死亡する恐れがあります。常に十分な注意を払い、事故防止規則を守ってください。
- 機械が起動したとき、可動部品および高電圧に注意してください。
- ポンプを長時間使用した後で保守作業を行わなければならない場合、冷めるまで待ってください。外部表面の温度は 60 °C を超えている場合があります。
- 保守作業を始める前に、必ずポンプへの電源を切り離してください。

注記



修理のためにポンプを工場へ返却する前に、本取扱説明書に添付されている「健康安全」の用紙に記入して、最寄の営業所に送付する必要があります。ポンプを送送する前に、用紙のコピーを同梱してください。

ポンプを廃棄する場合、該当する国内基準を守ってください。

사용 지침

일반 정보

본 장비는 전문가가 사용하도록 설계되었습니다. 사용자는 장비를 조작하기 전에 본 사용 설명서 및 Vacuum Technologies가 제공한 추가 정보를 주의 깊게 읽어야 합니다. Vacuum Technologies는 본 설명서 내용의 미준수, 교육받지 않은 작업자에 의한 부적절한 사용, 비승인 개조, 또는 정해진 국가 규정에 반하는 모든 행위에 의해 발생한 결과에 대해 아무런 책임도 지지 않습니다.

SH-110는 밀폐형 건식 스크롤 진공 펌프입니다. 이 펌프는 공기 또는 불활성 가스의 펌핑 작업에 적합합니다. 이 펌프는 유독성, 부식성, 폭발성 또는 미립자-성형 가스의 펌핑 작업용으로 고안되지 않았습니다.

다음 내용들은 본 장비 사용시에 작업자의 안전을 보장하기 위한 모든 필수 정보를 포함하고 있습니다. 상세한 정보는 15 페이지의 "Technical Information" 을 참조하십시오.

본 설명서는 다음과 같은 표준 안전 심볼을 사용합니다.



경고 메시지는 정확히 따르지 않을 경우 심각한 상해를 입을수 있는 특정 작업 절차 또는 작업 방법을 표시합니다.



주의 메시지는 작업 절차를 따르지 않을 경우 장비에 손상을 입힐 수 있는 주의 사항을 표시합니다.



참고는 알아두어야 할 중요 정보를 표시합니다.

보관

펌프를 운송하거나 보관할 때는 다음과 같은 환경적 조건들을 초과해서는 안됩니다.

온도: $-20^{\circ}\text{C} \sim +60^{\circ}\text{C}$ ($-4^{\circ}\text{F} \sim 140^{\circ}\text{F}$)

상대 습도: 0 ~ 95% (비응축)

설치 준비

이 펌프는 특수 보호 포장 상태로 공급됩니다. 운송 도중에 발생한 것으로 보이는 손상의 흔적이 있으면 현지의 판매 사무소로 연락하십시오.

SH-110 펌프를 포함한 포장품의 총 중량은 약 20 kg (44 lbs)입니다.



펌프를 포장할 때는 떨어뜨리거나, 갑작스러운 충격을 가하거나, 흔들리지 않도록 주의하십시오.



일반적인 상황에서는 펌프가 손상되지 않습니다. 하지만, 펌프를 시스템에 설치하기 전까지는 펌프의 흡입구를 막아 놓는 것이 좋습니다.

설치

비, 눈, 얼음, 먼지 또는 활성 가스에 노출되거나, 폭발 또는 화재 발생 우려가 있는 환경에서는 이 펌프를 설치하거나 사용하지 마십시오.

환경 조건이 다음과 같을 때만 작업하십시오.

온도: +5 °C ~ +40 °C (41 °F ~ 104 °F)

상대 습도: 0 ~ 95% (비응축)



주의

사용 장소의 메인 전압은 펌프 뒤쪽의 ON/OFF 스위치 근처에 있는 흰색 탭에 표시된 전압(110 또는 220)과 일치해야 합니다.

전압 변환이 필요할 경우에는 작은 크류 드라이버로 전원 모듈의 탭 홀더를 떼어 내십시오. 흰색 탭이 정확한 전압을 표시하도록 위치를 조정한 다음 탭 홀더를 다시 부착하십시오.

최하 10 A 정격의 IEC-320 형식 전원 코드를 사용하여 펌프와 전원 공급장치를 연결하십시오.

사용

최대의 진공 성능을 얻으려면 흡입구가 실링된 상태에서 약 1시간 정도 펌프를 구동시켜야 합니다.

특별한 펌프 작동 방법은 없습니다. ON/OFF 스위치를 ON에 놓기만 하면 됩니다.

흡입 밸브는 펌프가 구동되기 시작한 후 10초 정도 지나면 열립니다.



경고

이 펌프는 중성 또는 비부식성 용액의 펌핑 작업용으로 설계되었습니다. 폭발성, 인화성 또는 유독성 물질의 펌핑 작업에는 절대로 이 펌프를 사용하면 안 됩니다.

특별한 펌프 정지 방법은 없습니다. ON/OFF 스위치를 사용하여 전원 공급을 차단하기만 하면 됩니다.

펌프를 정지시키면 흡입 밸브는 즉시 닫힙니다.

유지 보수

펌프 작동 및 유지 보수 책임자는 충분한 교육을 받아야 하며, 사고 방지 지침을 철저히 인식하고 있어야 합니다.



경고

□ 고전압에 감전되어 목숨을 잃을 수도 있습니다. 각별한 주의를 기울임과 동시에 사고 방지 지침을 철저히 준수해야만 합니다.

□ 장비에 전원이 들어와 있을 때는 작동 부품 및 고전압에 각별히 주의하십시오.

□ 상당히 오랜 시간 동안 사용했을 경우에는, 펌프 표면 온도가 60°C 이하가 될 때까지 식힌 다음 유지 보수 작업을 실시하십시오.

□ 유지 보수 작업을 시작하기 전에 반드시 펌프와 전원 공급장치의 연결을 차단하십시오.



참고

펌프 수리를 위해 공장으로 반송할 경우에는 본 사용 설명서에 부착된 "보전 및 안전" 증명서를 작성하여 현지 판매 사무소로 보내야 합니다. 발송하기 전에, 증명서 사본 1부를 포장된 펌프에 동봉해야 합니다.

펌프는 정해진 국가 규정에 따라 폐기해야만 합니다.

SH-110 Dry Scroll Vacuum Pump

Technical Information

Table 1 Specifications

Model	SH-110 Dry Scroll Single Hermetic Vacuum Pump
Interface dimensions	See Figure 1 on page 16
Peak pumping speed	50 Hz: 90 L/m, 5.4 m ³ /hr (3.3 cfm) 60 Hz: 110 L/m, 6.6 m ³ /hr (4.0 cfm) See Figure 2 on page 16 for details
Media	No corrosive, explosive or particulate forming gases
Ultimate pressure	5.0 x 10 ⁻² Torr (6.6 x 10 ⁻² mbar)
Maximum inlet pressure	1.0 atmosphere (0 psig)
Maximum outlet pressure	1.5 atmosphere (7.5 psig)
Inlet connection	NW25
Exhaust connection	Female 1/4" National Pipe Thread (NW16 adapter provided)
Gas ballast	Female 1/8" National Pipe Thread, (20 micron sintered plug provided)
Ambient operating temperature	5 °C to 40 °C (41 °F to 104 °F)
Storage temperature	-20 °C to 60 °C (-4 °F to 140 °F)
Motor rating	0.25 HP (0.19 kW)
Operating voltages	1 phase/50-60 Hz/100-115:200-230 VAC
Run current	See Table 3 on page 20
Motor thermal protection	Automatic thermal protection
Operating speed	60 Hz: 1725 RPM, 50 Hz: 1425 RPM
Cooling system	Air-cooled
Weight	Pump only: 19.5 kg (43 lbs) Shipping weight: 20 kg (44 lbs)
Leak rate (with exhaust sealed)	<1 x 10 ⁻⁷ sccs helium
Noise Level (per ISO 11201)	56 dB(A)
Vibration level at inlet (per ISO 10816-1)	Class 1B, 1.5 mm/s
Fuse type	M5 x 20 mm, 10 A, Slo-Blo, Littelfuse Model H215010 or equivalent
Hour meter	Integral Hour Meter provided, displays running time to closest .1 hour
Conformance standards	Conforms to SEMI S2-2000 and applicable CSA, CUS, and CE standards.

SH-110 Dry Scroll Vacuum Pump

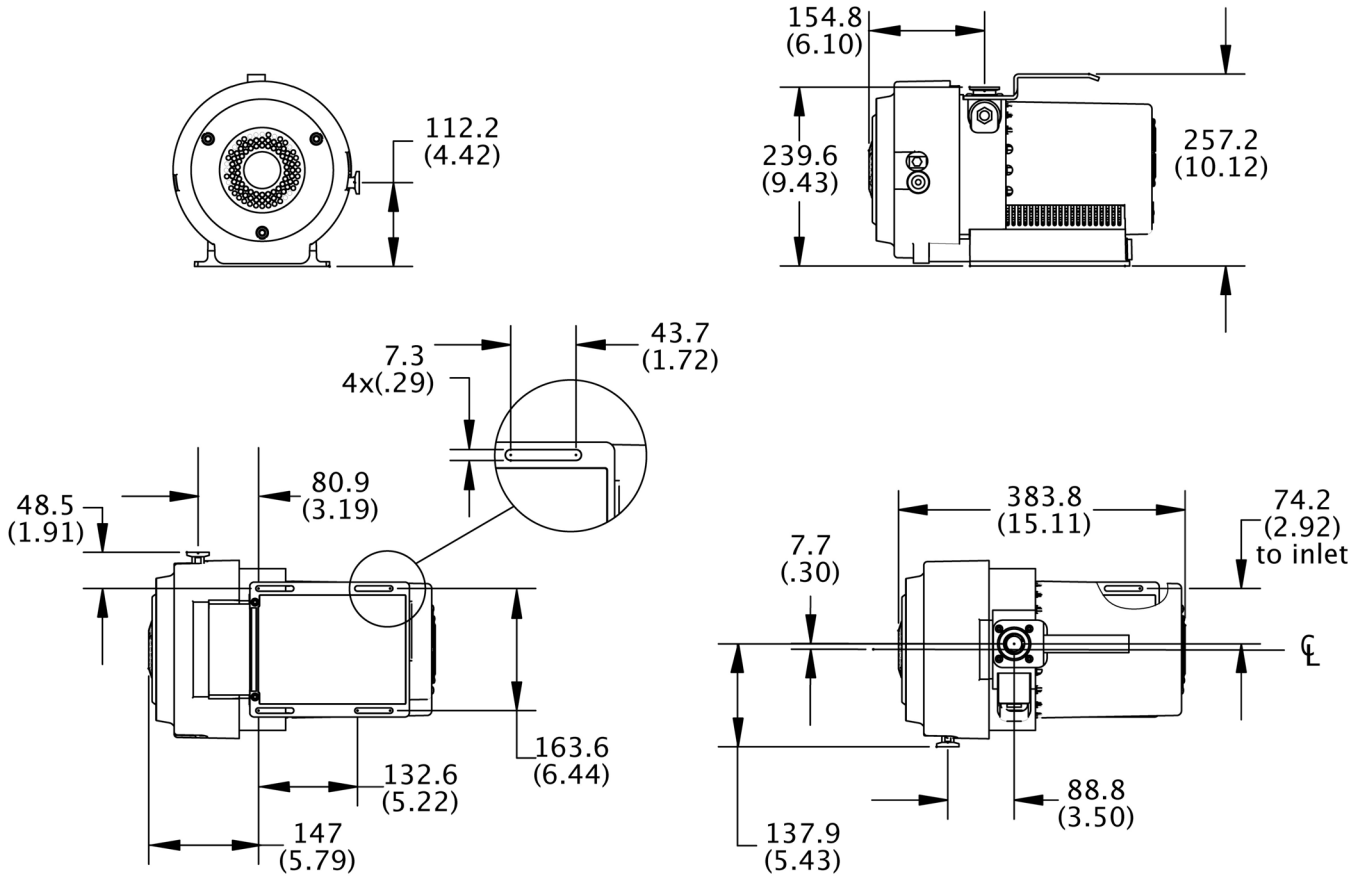

Figure 1 Interface Drawing with Dimensions

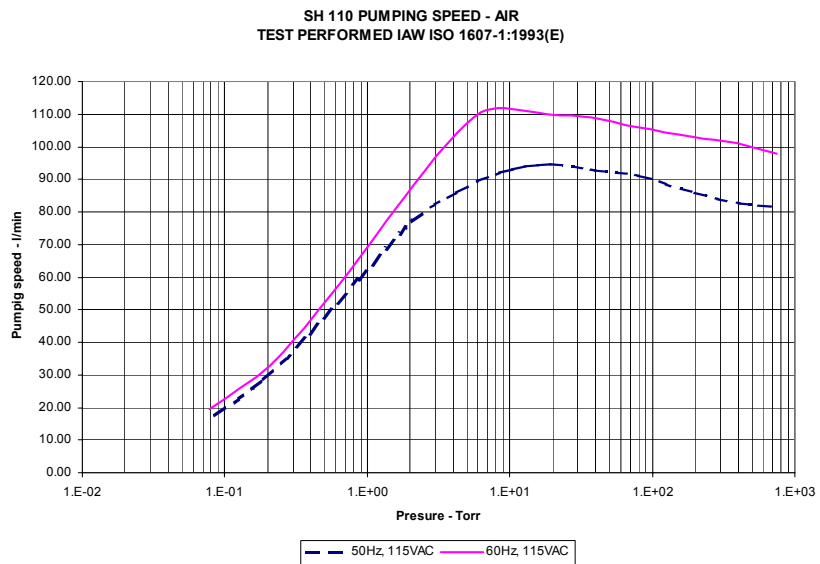
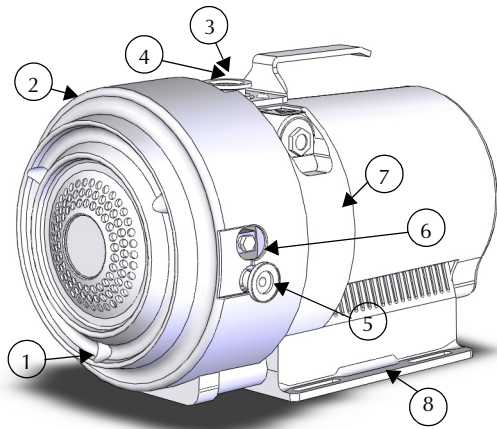
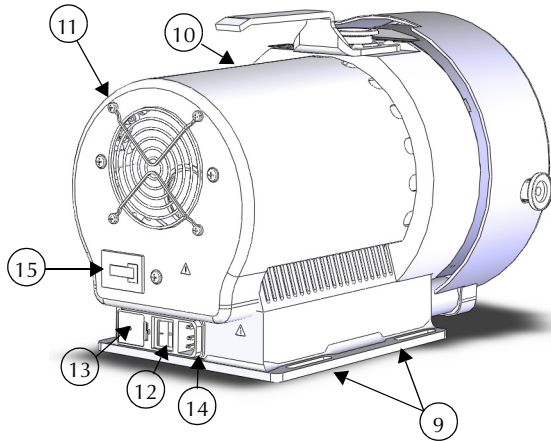

Figure 2 Pumping Speed Curves

SH-110 Dry Scroll Vacuum Pump



1. Front Cowling Screws; M8 (3)
2. Front Cowling
3. Inlet (NW25)
4. Inlet Screen
5. Exhaust Adapter NW16
6. Gas Ballast Port (1/8" National Pipe Thread)
7. Frame
8. Base
9. Mounting Slots; (4) for 1/4" or M6 Hardware
10. Rear Cowling
11. Rear Cowling Screws: M5 (3)
12. On/Off Switch
13. Fuse Holder and Voltage Changeover Tab
14. Power Connection (IEC-320)
15. Hour Meter



Unpacking and Inspection

1. Orient the shipping container with "This End Up" on top.
2. Open the box and remove the upper foam block.
3. Carefully lift the SH-110 out of the box. Save the carton and all packing materials.
4. Inspect the pump for damage. If there is shipping damage, contact the freight carrier and your local Vacuum Technologies sales office immediately.

Figure 3 Outline Drawing and Principal Items

SH-110 Dry Scroll Vacuum Pump

Installation

Safety

Do not remove or modify any safety or insulating equipment from the pump. To do so may create a serious safety hazard and may void the warranty.

WARNING



- ❑ *This pump is capable of pumping air and inert gases only. It is not designed to pump explosive, flammable, corrosive or particulate forming gases. They can cause bodily injury, explosion, or fire.*
- ❑ *Install in an area that is not exposed to rain, steam, or excessive humidity. They can cause electric shock, short circuits, and severe bodily injury.*
- ❑ *Before reconfiguring the pump voltage, or inspecting or servicing the pump, be sure the electrical supply is disconnected.*
- ❑ *The gas ballast must be sealed whenever pumping any gas not intended to be vented to the atmosphere.*

CAUTION



Although the pump can pump trace particulates normally found in the atmosphere, it is not designed to process solids, chemicals, powders, solvents, condensates, or other particulates. They can damage the equipment, degrade its performance, or shorten its useful life.

Startup

1. Check that the inlet screen is installed before beginning operation.

WARNING



Do not insert a finger or any foreign object in the path of the fan; serious personal injury may result or the pump may be damaged.

2. Operate the pump at an ambient temperature of 5 °C to 40 °C (41 °F to 104 °F), otherwise damage to the pump or shortened operating life may result.

CAUTION



Do not block the fan ducts. Blocking these ducts can cause pump overheating. A pump surface temperature in excess of 65 °C (150 °F) is potentially damaging. If such conditions are observed, turn the pump off and allow it to cool. Disassemble, inspect for damage, and repair, if necessary.

Electrical Connections

The pump can be configured for low voltage, 100 VAC to 115 VAC, or for high voltage, 200 VAC to 230 VAC.

The pump as delivered from the factory is configured for low voltage. To change the pump voltage follow this procedure:

WARNING



Risk of electric shock. Disconnect the pump from electrical power mains before attempting to change the voltage configuration.

1. Verify your electrical supply voltage.
2. Use a small flat blade screwdriver to release the fuse holder from the power entry module.
3. Carefully pop out the white plastic assembly and reinsert with the desired operating voltage showing outward.
4. Reinsert the fuse holder into the power entry module.

SH-110 Dry Scroll Vacuum Pump

Power Cord

Several power cord options are available from your Vacuum Technologies dealer. Descriptions of the available power cords and their ordering numbers are given in Table 2.

NOTE



For high voltage operation, the pump must be connected to the power supply using a high voltage IEC-320 type power cord of at least 10 A capacity.

Table 2 SH-110 Power Cord Selection

Country	Power Cord Specification	Order
Europe	10 A / 220-230 VAC, 2.5 m	656494220
Denmark	10 A / 220-230 VAC, 2.5 m	656494225
Switzerland	10 A / 230 VAC, 2.5 m	656494235
UK/Ireland	13 A / 230 VAC, 2.5 m	656494250
India	10 A / 220-250 VAC, 2.5 m	656494245
Israel	10 A / 230 VAC, 2.5 m	656494230
Japan	12 A / 100 VAC, 2.3 m	656494240
North America	15 A / 125 VAC, 2.0 m	656458203
	10 A / 230 VAC, 2.5 m	656494255

Grounding Instructions

This product should be grounded. In the event of an electrical short circuit, grounding reduces the risk of electric shock by providing an escape wire for the electric current. This pump is equipped with a power cord that has a grounding wire with an appropriate grounding plug. The plug must be inserted into an outlet that is properly installed and grounded in accordance with all local codes and ordinances.

DANGER



Improper installation of the grounding plug can result in a risk of electrical shock.

For United States and Canadian installations:

- When this product is configured for use on a nominal 120 V circuit, it must be used with a grounding plug that looks like the plug illustrated in Figure 4.*
- If repair or replacement of the cord or plug is necessary, connect the grounding wire to the grounding terminal only.*
- The grounding wire is insulated and its outer surface is green. It may or may not have yellow stripes.*
- When this product is configured for use on a nominal 220 V circuit, it must be used with a factory supplied cord and plug that permits connection to the proper electric circuit. See “Electrical Connections” on page 18 for proper rating and type of cord set.*

WARNING



Check with a qualified electrician or serviceman if the grounding instructions are not completely understood, or if you are in doubt as to whether the product is properly grounded.

Do not modify the plug provided; if it does not fit the outlet, have the proper outlet installed by a qualified electrician.

Connect the product only to an outlet that has the same configuration as the plug.

Do not use an adapter with this product.

SH-110 Dry Scroll Vacuum Pump

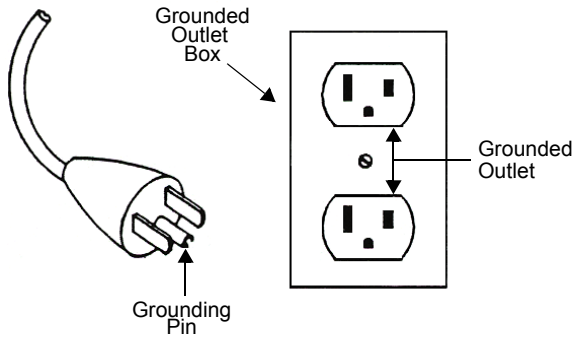

Figure 4 Grounding Plug and Outlet

Extension Cords

If you must use an extension cord with this product:

- For this product, Vacuum Technologies recommends using only extension cords with a minimum of 16-gage wire and a maximum length of 25 feet (7.6 m).
- Use only a 3-wire extension cord that will accept the plug.
- Make sure your extension cord is in good condition.
- Be sure the extension cord is rated high enough to carry the current your product will draw. An undersized cord will cause a drop in line voltage resulting in loss of power and overheating.

WARNING



If the product must be reconnected for use on a different type of electric circuit, the connector should be replaced by qualified service personnel.

Run Currents

Typical run currents listed in Table 3 are approximately constant from minimum to maximum intake pressure.

Table 3 SH-110 Typical Run Currents

Frequency	Low Voltage Range				High Voltage Range			
	90 V	100 V	115 V	126 V	180 V	200 V	230 V	252 V
60 Hz	4.4	4.2	4.0	3.7	2.2	2.1	2.0	1.9
50 Hz	4.1	4.1	4.2	4.2	2.1	2.1	2.1	2.1

Start Current

Table 4 lists the typical SH-110 maximum starting current and duration.

Table 4 Typical SH-110 Maximum Starting Current and Duration @ 115 V

50 Hz		60 Hz	
Current (A)	Time (ms)	Current (A)	Time (ms)
24	250	26	250

SH-110 Dry Scroll Vacuum Pump

Mechanical Connections

Isolation Valve

The SH-110 has an integral automatic isolation valve. An internal timer opens the valve 10 seconds after the pump is switched ON. If power is lost or the pump is switched OFF, the isolation valve will immediately close.

Pump Inlet

Use NW25, or larger, clean vacuum hardware with as short a length as practical between the pump and vacuum chamber.

Insert a bellows between the pump and vacuum chamber to provide both vibration isolation and strain relief.

Pump Exhaust

A female 1/4" National Pipe Thread exhaust fitting is located radially near the front of the pump. Additionally, an NW16 male adapter with 1/4" National Pipe Thread is provided. To avoid overheating the pump, do not restrict the exhaust flow with long lengths of small diameter tubing. Use as short as practical lengths of NW16, or larger, diameter hardware.

Gas Ballast

The pump incorporates an automatic gas ballast to prevent water and other condensates from accumulating within the pump. The standard configuration has a solid plug installed in the 1/8" National Pipe Thread gas ballast port (item 6 on Figure 3 on page 17). This configuration can be used for relatively dry applications. A sintered filter plug is also supplied with the pump. The filter plug can be installed in the gas ballast port and will allow enough atmospheric air to enter the pump to purge condensates while not affecting pump ultimate pressure or pumping speed.

For applications where the ingress of atmospheric air is undesirable, dry nitrogen at a flow rate of approximately 2 L/m can be bled into the gas ballast port.

WARNING



The gas ballast must be sealed whenever pumping any gas not intended to be vented to atmosphere.

Operation

Cleaning the Pump

Unlike conventional oil-sealed pumps, Vacuum Technologies dry scroll pumps do not contain fluid for the cleansing of accumulated dust and debris. Run the pump periodically at atmosphere for a minute or two to flush it out. Until experience is gained on your specific process, flush the pump regularly and adjust this schedule according to your specific conditions.

Startup Procedure

1. Make sure that the pump is configured for the mains voltage to which the pump is connected.

NOTE



The pump ON/OFF switch is a rocker type switch that has symbols in accordance with IEC Publication 417 to represent the ON and OFF positions. Figure 5 shows a switch in the ON position.

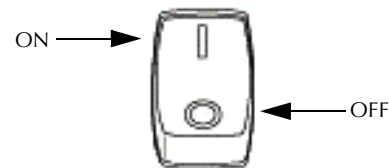

Figure 5 ON/OFF Power Switch

2. Switch the pump ON.
3. The isolation valve will open automatically 10 seconds after starting the pump.

Shutdown Procedure

To shutdown the pump:

1. Switch the pump OFF.

The isolation valve will close very quickly to isolate the vacuum chamber from the pump.

SH-110 Dry Scroll Vacuum Pump

Troubleshooting

Use the Troubleshooting chart in Table 5 to assist in defining a problem, determining a possible cause, and defining action steps to remedy the situation.

Table 5 Troubleshooting Chart

Problem	Possible Causes	Corrective Actions
Will not start	One or both fuses blown	Replace fuses. Identify cause of overload. Check the line voltage and the voltage configuration of the pump.
	Motor thermal protector open	Allow motor to cool. Identify cause of overload.
	Excessive voltage drop	Check size and length of cable.
	Defective motor	Inspect. Contact Vacuum Technologies.
Poor ultimate pressure	System leak	Locate and repair leak.
	Water in pump	Flush pump with air or dry nitrogen.
	Gas ballast plugged	Replace breather vent. Contact Vacuum Technologies.
	Solvent in pump	Flush pump with air or dry nitrogen. Install trap or filter.
	Seals worn out	Rebuild pump.
	Poor conductance to pump	Replumb with shorter and/or larger diameter tubing.
Hammering noise	Pump overheated	Check ventilation to pump. Check ambient temperature.
	Debris in pump	Check intake screen. Flush pump. Disassemble pump and inspect.
Pump runs intermittently	Motor thermal protector is cycling open and closed.*	Allow the motor to cool. Identify the cause of the overload.

* *The SH-110 is equipped with an auto-reset thermal motor protector. This protector will automatically shut down the pump when it detects an overload condition, and will automatically restart the pump when the motor has cooled to within an acceptable temperature range.*

SH-110 Dry Scroll Vacuum Pump

Maintenance

Kits and Service Options

Vacuum Technologies pumps will provide many years of trouble-free service if the maintenance procedures and intervals are observed. Cleaning and tip seal replacement are recommended when pump base pressure has risen to an unacceptably high level for your application. If your pump exhibits humming or grinding noises from the bearings, a major overhaul should be done by Vacuum Technologies or an authorized rebuild center. Advance exchange pumps are available to minimize downtime.

The parts needed for tip seal replacement on the SH-110 are available in the kit described in Table 6. This kit contains seals and O-rings, and can be obtained from your Vacuum Technologies dealer.

Table 6 Tip Seal Replacement Kit

Part Number	Description	Contents
SH0110TS	Replacement Tip Seal Set	Replacement Tip Seals and O-rings for SH-110 pumps

Factory Service

Vacuum Technologies offers rebuilding service at our factory, or you can obtain advance exchange of complete SH-110 pumps. The service plans available and their ordering numbers are given in Table 7.

Table 7 Factory Service Options

Factory Service Plans	Model Number
Advance Exchange SH-110 Pump	EXSH01101UNIV
Service/Rebuild SH-110	RPSH01101UNIV

Cleaning

Exterior

The exterior surfaces of the SH-110 may be cleaned with alcohol or mild detergents only.

Interior

Run the pump periodically at atmosphere for a minute or two to flush it out. For more information, see "Cleaning the Pump" on page 21.

Tip Seal Replacement

The parts and tools required to replace tip seals are listed below:

- Tip Seal Replacement Kit P/N SH0110TS
- 4 and 8 mm Allen wrenches
- 14 mm crescent wrench
- Razor blade or side-cutting pliers
- Compressed air (optional)

WARNING



If dangerous gases were being pumped, flush the pump with air or inert gas for at least 10 minutes prior to disassembly.

Figure 6 on page 24 shows the various components involved in a tip seal replacement procedure. Refer to Figure 6 as you follow the procedure.

To remove the worn tip seals:

1. Disconnect the pump from electrical power.
2. Remove (3) M8 socket head bolts (item 1).
3. Using a crescent wrench, remove the exhaust adapter (item 2).
4. Remove the front cowling and hang out of the way (item 3). Do not unplug.
5. Remove (4) M5 bolts (item 4).
6. Remove the scroll housing axially off the frame (item 5).
7. Remove and discard the worn tip seals (item 6) and the main O-ring (item 7).
8. If compressed air is available, blow any remaining seal debris off the scroll parts. If seal debris is attached to the sides, use a razor or Exacto knife to scrape the debris off.

To install the new seals and O-rings:

1. Unpack the Tip Seal.
2. Install the closed loop portion of the Tip Seal onto the Orbiting Scroll (item 9).
3. Sequentially insert the seal from center to the outer edge of the scroll wall.
4. Cut the Tip Seal about 1/8" (3 mm) from the groove end.
5. Use the remaining Tip Seal material to fill the seal groove on the Scroll Housing and again trim the excess Tip Seal so that a gap of about 1/8" (3 mm) remains.
6. Place the new main O-ring onto the Frame (item 10). Make sure the area where the O-ring sits is clean.

SH-110 Dry Scroll Vacuum Pump

- Carefully replace the Scroll Housing making sure to line up the Locating Pins. Be sure that the Tip Seal has not fallen out of its groove.
- Reinstall (4) M5 bolts (item 4). Torque the (4) M5 bolts to 4 N-m (40 in-lbs).
- Place the front cowling in place and replace the M8 bolts.
- Reinstall the exhaust valve.
- Reconnect the pump to the electrical power mains.

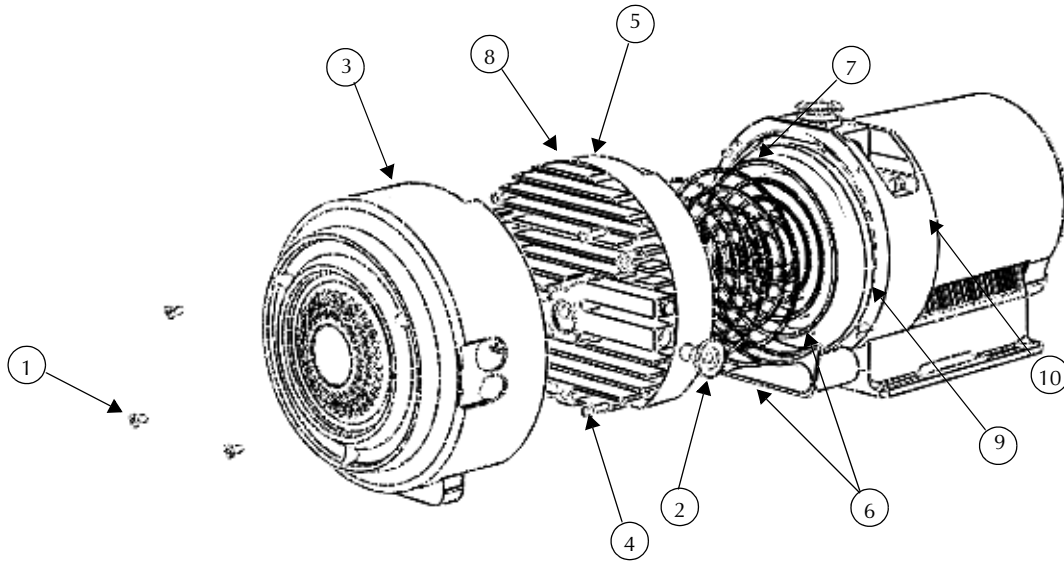

Figure 6 Exploded View of Pump Body

- | | |
|---------------------------------|---------------------------|
| 1. Front Cowling Bolts; M8 (3) | 2. Exhaust Adapter (NW16) |
| 3. Front Cowling | 4. Frame Bolts; M5 (4) |
| 5. Scroll Housing | 6. Tip Seals |
| 7. Main O-ring Parker No. 2-168 | 8. Locating Pins (2) |
| 9. Orbiting Scroll | 10. Frame |

To test the pump:

- Run the pump for about 5 seconds. Verify that the front fan is running.
If you hear loud noises or observe labored operation, this indicates that the Tip Seal or main O-ring are possibly out of place.
- Disassemble and repair as necessary.
The pump is now ready to return to service.

NOTE



Newly installed Tip Seals may require several hours of run time to seat properly and enable the pump to meet speed and base pressure specifications.



*Request for Return
Health and Safety Certification*



- Return authorization numbers (RA#) **will not** be issued for any product until this Certificate is completed and returned to a Varian, Inc. Customer Service Representative.
- Pack goods appropriately and drain all oil from rotary vane and diffusion pumps (for exchanges please use the packing material from the replacement unit), making sure shipment documentation and package label clearly shows assigned Return Authorization Number (RA#) VVT cannot accept any return without such reference.
- Return product(s) to the nearest location:

North and South America

Varian, Inc.
Vacuum Technologies
121 Hartwell Ave.
Lexington, MA 02421
Fax: (781) 860-9252

Europe and Middle East

Varian S.p.A.
Via F.lli Varian, 54
10040 Leini (TO) – ITALY
Fax: (39) 011 997 9350

Asia and ROW

Varian Vacuum Technologies
Local Office

For a complete list of phone/fax numbers see www.varianinc.com/vacuum

- If a product is received at Varian, Inc. in a contaminated condition, **the customer is held responsible** for all costs incurred to ensure the safe handling of the product, and **is liable** for any harm or injury to Varian, Inc. employees occurring as a result of exposure to toxic or hazardous materials present in the product.

CUSTOMER INFORMATION		
Company name:		
Contact person: Name:	Tel:.....	
Fax:	E-mail:	
Ship method:	Shipping Collect #:	P.O.#:
Europe only: VAT Reg Number:	USA only: <input type="checkbox"/> Taxable <input type="checkbox"/> Non-taxable	
Customer ship to:	Customer bill to:	
.....	
.....	

PRODUCT IDENTIFICATION

Product Description	Varian, Inc. Part Number	Varian, Inc. Serial Number

TYPE OF RETURN (check appropriate box)

<input type="checkbox"/> Paid Exchange	<input type="checkbox"/> Paid Repair	<input type="checkbox"/> Warranty Exchange	<input type="checkbox"/> Warranty Repair	<input type="checkbox"/> Loaner Return
<input type="checkbox"/> Credit	<input type="checkbox"/> Shipping Error	<input type="checkbox"/> Evaluation Return	<input type="checkbox"/> Calibration	<input type="checkbox"/> Other

HEALTH and SAFETY CERTIFICATION

VACUUM TECHNOLOGIES CANNOT ACCEPT ANY BIOLOGICAL HAZARDS, RADIOACTIVE MATERIAL, ORGANIC METALS, OR MERCURY AT ITS FACILITY. CHECK ONE OF THE FOLLOWING:		
<input type="checkbox"/> I confirm that the above product(s) has (have) NOT pumped or been exposed to any toxic or dangerous materials in a quantity harmful for human contact.		
<input type="checkbox"/> I declare that the above product(s) has (have) pumped or been exposed to the following toxic or dangerous materials in a quantity harmful for human contact (<u>Must be filled in</u>):		
Print Name.....	Signature	Date

PLEASE FILL IN THE FAILURE REPORT SECTION ON THE NEXT PAGE

Do not write below this line

Notification (RA) #:..... Customer ID #: Equipment #:.....

FAILURE REPORT

(Please describe in detail the nature of the malfunction to assist us in performing failure analysis):

TURBO PUMPS AND TURBOCONTROLLERS

Claimed Defect	Position	Parameters
<input type="checkbox"/> Does not start <input type="checkbox"/> Does not spin freely <input type="checkbox"/> Does not reach full speed <input type="checkbox"/> Mechanical Contact <input type="checkbox"/> Cooling defective <input type="checkbox"/> Noise <input type="checkbox"/> Vibrations <input type="checkbox"/> Leak <input type="checkbox"/> Overtemperature <input type="checkbox"/> Clogging	<input type="checkbox"/> Vertical <input type="checkbox"/> Horizontal <input type="checkbox"/> Upside-down <input type="checkbox"/> Other	Power: Rotational Speed: Current: Inlet Pressure: Temp 1: Foreline Pressure: Temp 2: Purge flow: Operation Time:
Describe Failure:		
Turbocontroller Error Message:		

ION PUMPS/CONTROLLERS

<input type="checkbox"/> Bad feedthrough <input type="checkbox"/> Vacuum leak <input type="checkbox"/> Error code on display <input type="checkbox"/> Poor vacuum <input type="checkbox"/> High voltage problem <input type="checkbox"/> Other
Describe failure:
Customer application:

VALVES/COMPONENTS

<input type="checkbox"/> Main seal leak <input type="checkbox"/> Solenoid failure <input type="checkbox"/> Damaged sealing area <input type="checkbox"/> Bellows leak <input type="checkbox"/> Damaged flange <input type="checkbox"/> Other
Describe failure:
Customer application:

LEAK DETECTORS

<input type="checkbox"/> Cannot calibrate <input type="checkbox"/> Vacuum system unstable <input type="checkbox"/> Failed to start <input type="checkbox"/> No zero/high background <input type="checkbox"/> Cannot reach test mode <input type="checkbox"/> Other
Describe failure:
Customer application:

INSTRUMENTS

<input type="checkbox"/> Gauge tube not working <input type="checkbox"/> Communication failure <input type="checkbox"/> Error code on display <input type="checkbox"/> Display problem <input type="checkbox"/> Degas not working <input type="checkbox"/> Other
Describe failure:
Customer application:

ALL OTHER VARIAN, INC.

<input type="checkbox"/> Pump doesn't start <input type="checkbox"/> Doesn't reach vacuum <input type="checkbox"/> Pump seized <input type="checkbox"/> Noisy pump (describe) <input type="checkbox"/> Overtemperature <input type="checkbox"/> Other
Describe failure:
Customer application:

DIFFUSION PUMPS

<input type="checkbox"/> Heater failure <input type="checkbox"/> Doesn't reach vacuum <input type="checkbox"/> Vacuum leak <input type="checkbox"/> Electrical problem <input type="checkbox"/> Cooling coil damage <input type="checkbox"/> Other
Describe failure:
Customer application:

