

# Bipolar transistors

---

# bipolar transistors

npn transistor

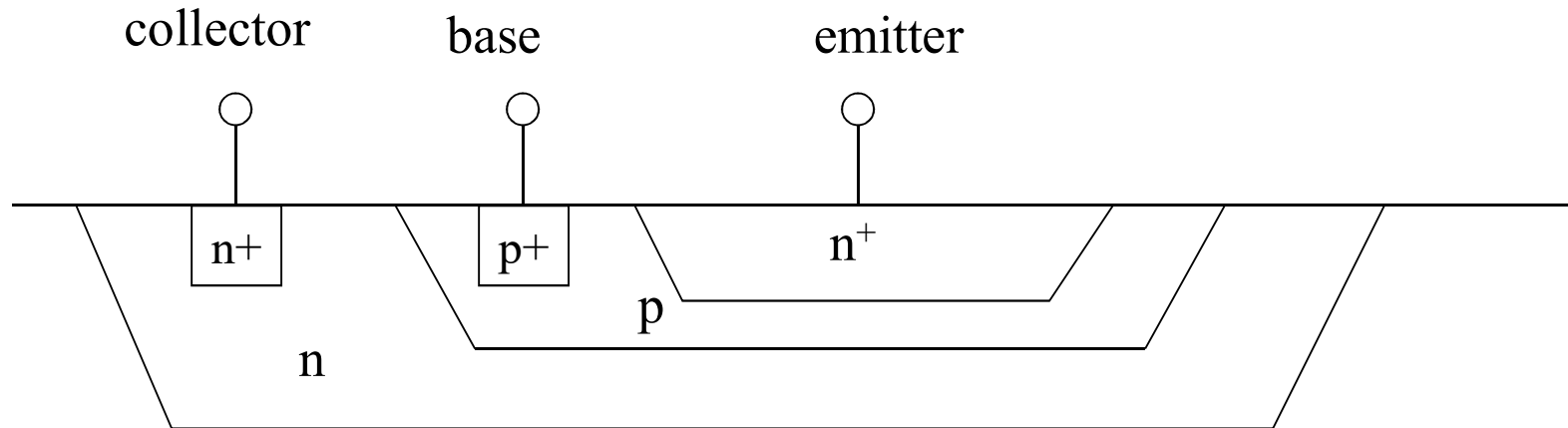

lightly doped p substrate

Used in front-end high-frequency receivers (mobile telephones), low input impedance amplifiers, power devices.

# bipolar transistors

---

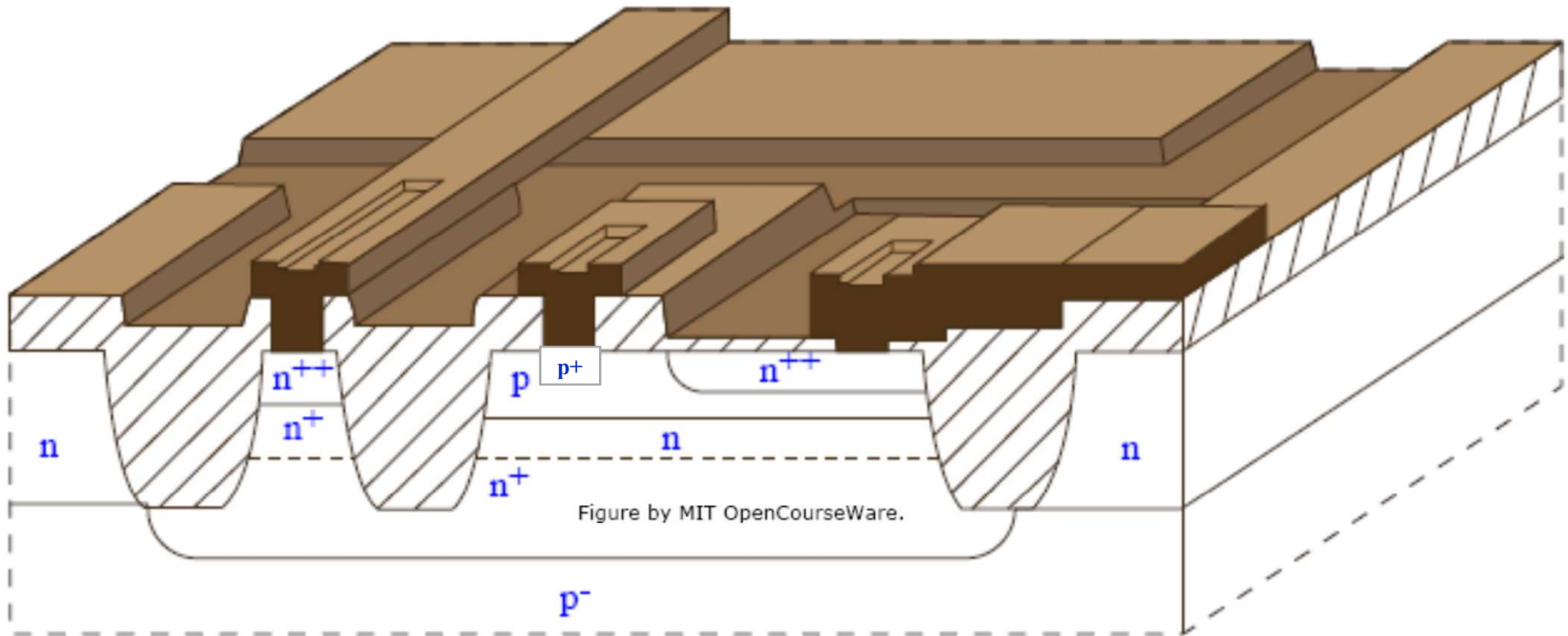
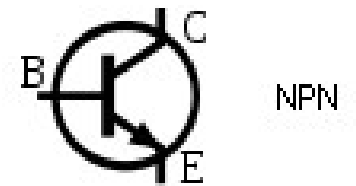
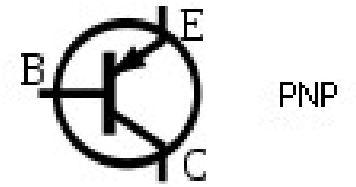

**Oxide isolated integrated BJT - a modern process**

# abrupt junction

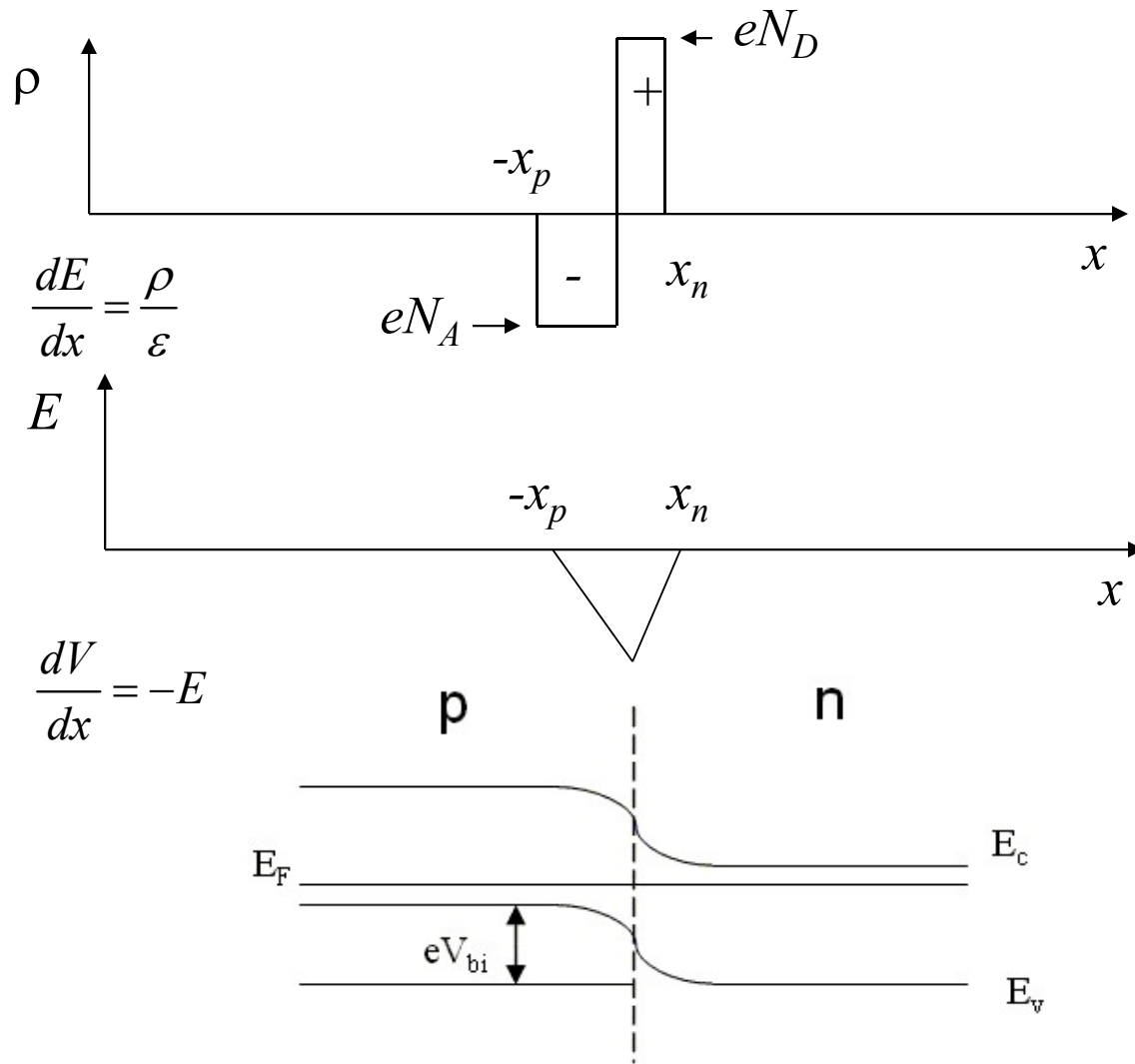

$$eV_{bi} = k_B T \ln \left( \frac{N_D N_A}{n_i^2} \right)$$

$$E = -\frac{eN_A}{\epsilon} (x + x_p) \quad -x_p > x > 0$$

$$E = \frac{eN_D}{\epsilon} (x - x_n) \quad 0 > x > x_n$$

$$V = \frac{eN_A}{\epsilon} \left( \frac{x^2}{2} + xx_p \right) \quad -x_p > x > 0$$

$$V = \frac{-eN_D}{\epsilon} \left( \frac{x^2}{2} - xx_n \right) \quad 0 > x > x_n$$

# Forward bias, $V > 0$

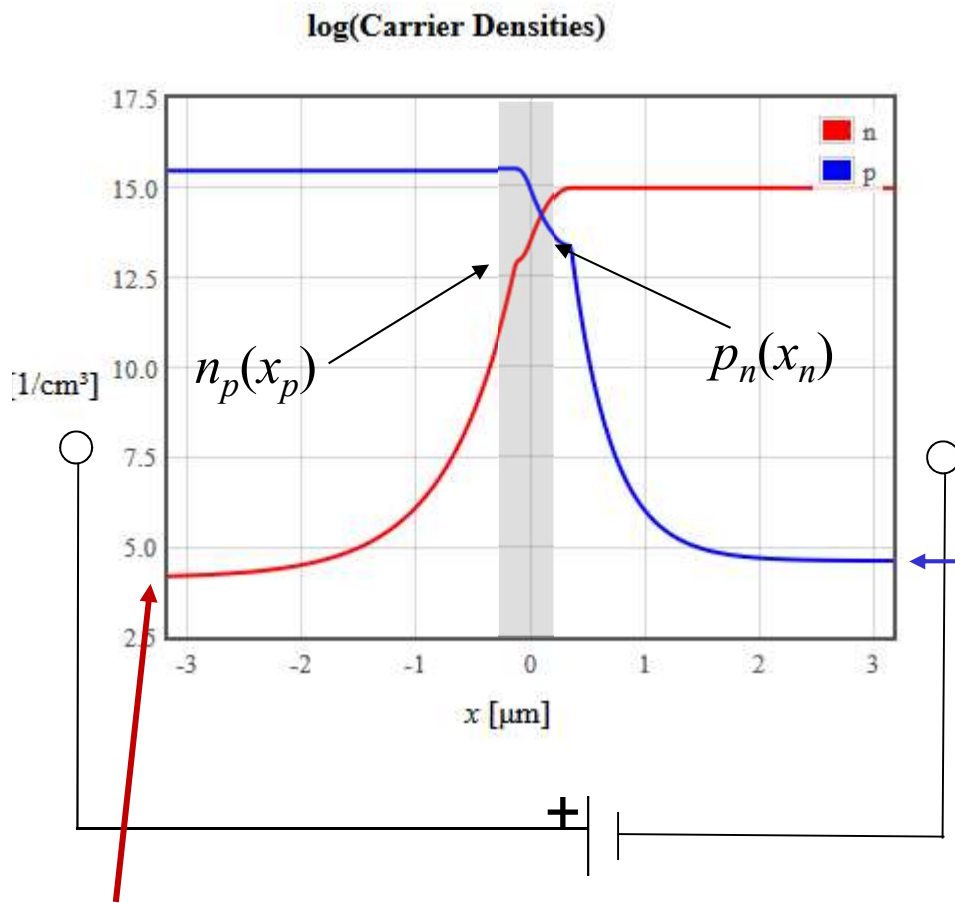

Electrons and holes are driven towards the junction.  
The depletion region becomes narrower

$$n_p(x_p) = n_{p0} \exp\left(\frac{eV}{k_B T}\right)$$

$$p_n(x_n) = p_{n0} \exp\left(\frac{eV}{k_B T}\right)$$

$$n_{p0} = \frac{n_i^2}{N_A}$$

Minority electrons are injected into the p-region  
Minority holes are injected into the n-region

# Reverse bias, $V < 0$

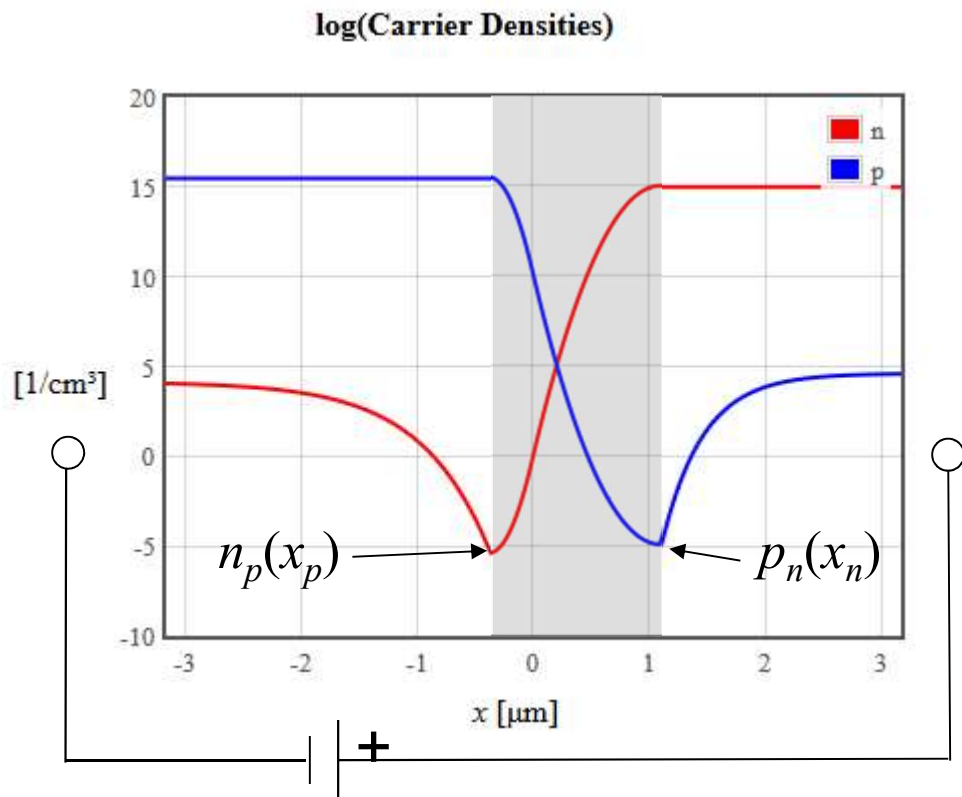

Electrons and holes are driven away from the junction.

The depletion region becomes wider

$$n_p(x_p) = n_{p0} \exp\left(\frac{eV}{k_B T}\right)$$

$$p_n(x_n) = p_{n0} \exp\left(\frac{eV}{k_B T}\right)$$

Minority electrons are extracted from the p-region by the electric field  
Minority holes are extracted from the n-region by the electric field

# Long/Short diodes

$N_A = 1E15$   $1/cm^3$      $N_D = 1E15$   $1/cm^3$      $E_g = 1.166-4.73E-4*T*T/(T+636)$  eV     $d_p = -2$   $\mu m$   
 $N_v(300) = 9.84E18$   $1/cm^3$      $N_c(300) = 2.78E19$   $1/cm^3$      $\epsilon_r = 12$      $T = 300$  K     $d_n = 2$   $\mu m$   
 $\mu_p = 480$   $cm^2/V s$      $\mu_n = 1350$   $cm^2/V s$      $\tau_p = 1E-7$  s     $\tau_n = 1E-7$  s  
 $V = 0.2$  V   

$E_g = 1.12$  eV     $W = |x_n| + |x_p| = 1.05$   $\mu m$      $x_p = -0.527$   $\mu m$      $x_n = 0.527$   $\mu m$      $V_{bi} = 0.618$  V     $n_i = 6.41e+9$   $cm^{-3}$   
 $D_p = 12.4$   $cm^2/s$      $D_n = 34.9$   $cm^2/s$      $L_p = 11.1$   $\mu m$      $L_n = 18.7$   $\mu m$      $n_{p0} = 4.10e+4$   $cm^{-3}$      $p_{n0} = 4.10e+4$   $cm^{-3}$   
 $A_n = -5.35e+8$   $cm^{-3}$      $B_n = 6.62e+8$   $cm^{-3}$      $A_p = 4.24e+8$   $cm^{-3}$      $B_p = -2.96e+8$   $cm^{-3}$   
 $j_n = 0.00000357$  A  $cm^{-2}$      $j_p = 0.00000128$  A  $cm^{-2}$      $j_{diff} = 0.00000485$  A  $cm^{-2}$

Minority Carrier Densities

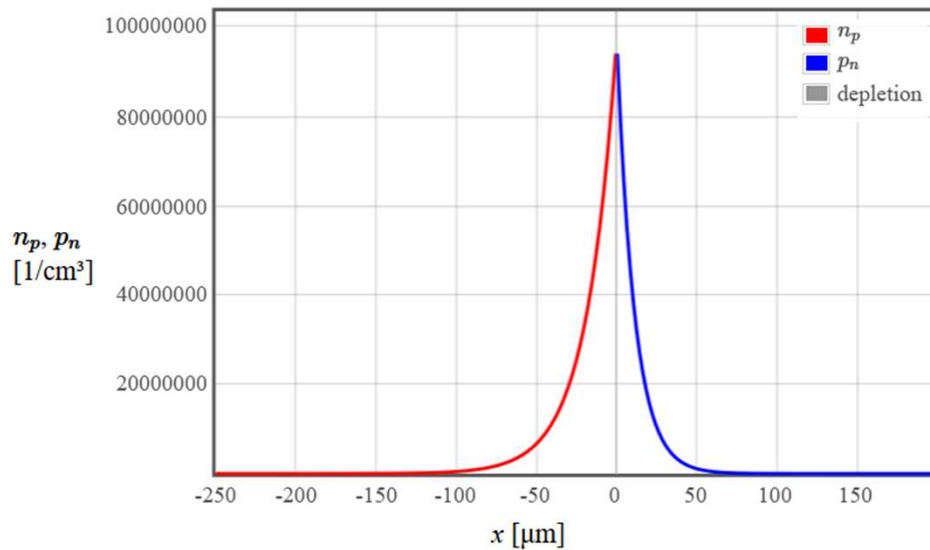

$\log_{10}$ (Minority Carrier Densities)

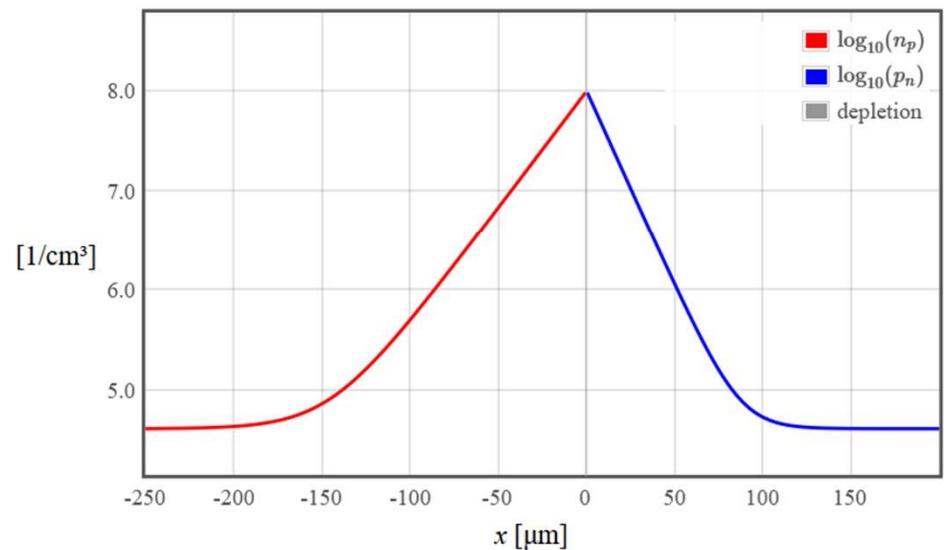

# pnp transistor, no bias

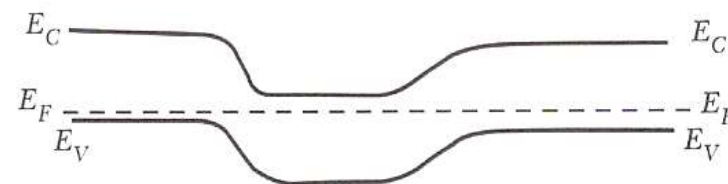
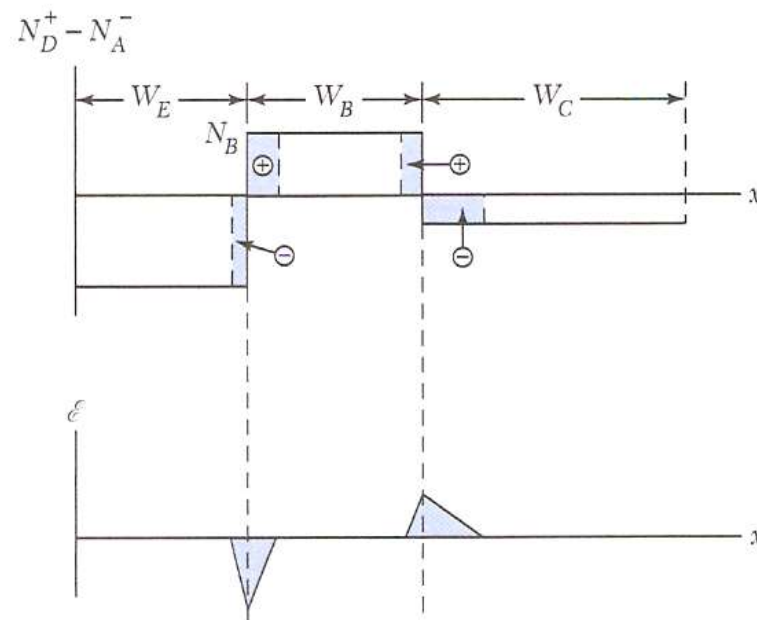
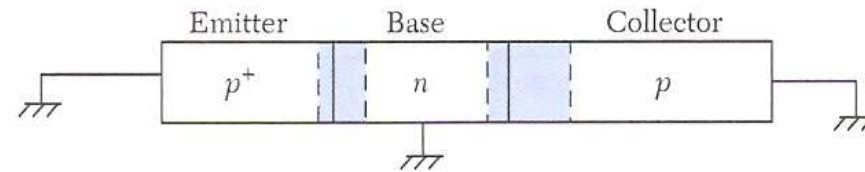



# pnp transistor, forward active bias

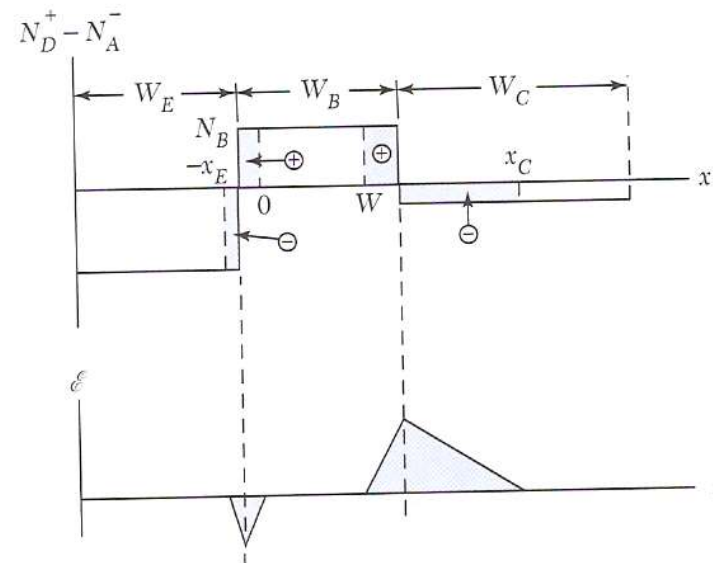
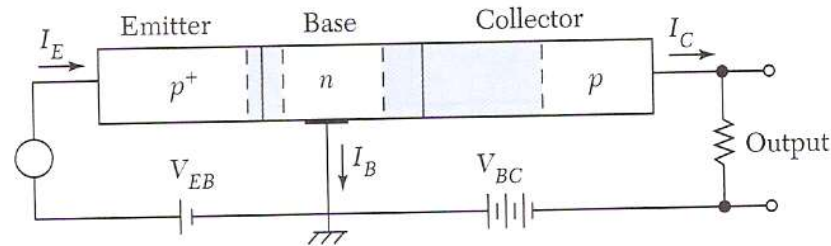

Always dissipate power due to the forward bias

The base-emitter voltage controls the minority carriers injected from the emitter to the base. These diffuse to the base-collector junction and are swept into the collector.

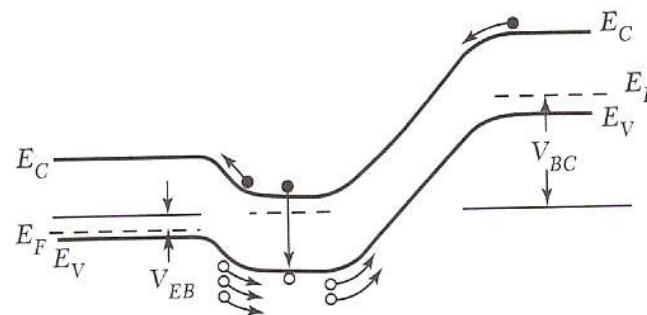

# Minority carrier concentration

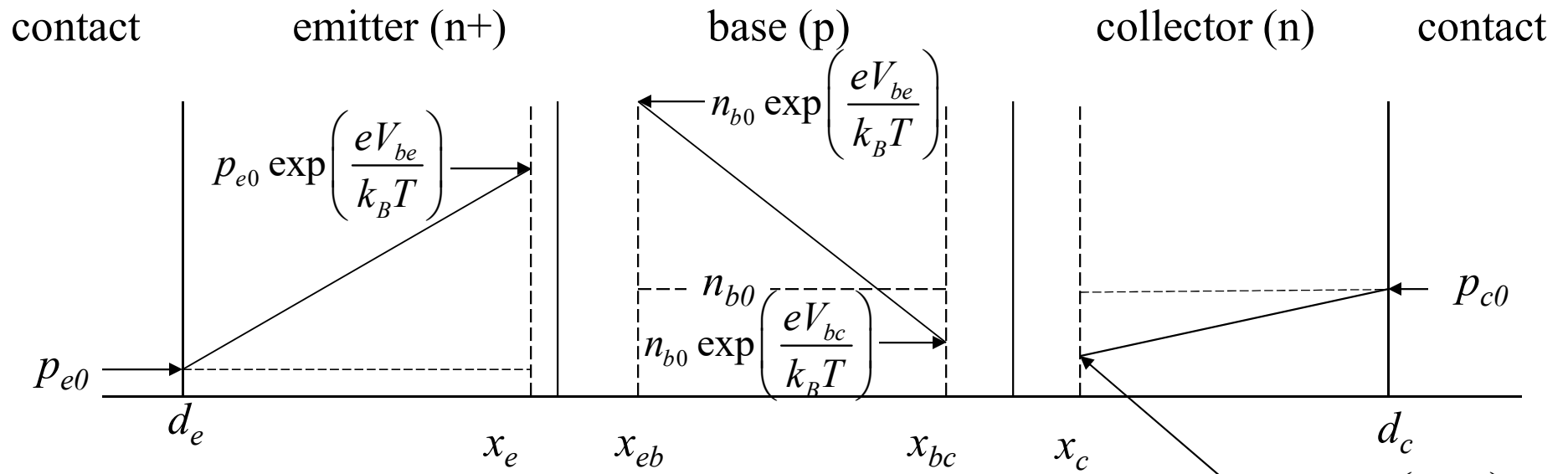

$$I_{Ep} = -eA_{be}D_p \frac{p_{e0}(e^{eV_{be}/k_B T} - 1)}{x_e - d_e}$$

$$I_{En} = eA_{be}D_n \frac{n_{b0}(e^{eV_{bc}/k_B T} - e^{eV_{be}/k_B T})}{x_{bc} - x_{be}}$$

# Emitter current

$$I_E = I_{En} + I_{Ep} = \left[ \frac{eA_{be}D_p p_{e0}}{x_{eb} - d_e} + \frac{eA_{be}D_n n_{b0}}{x_{bc} - x_{be}} \right] (e^{eV_{be}/k_B T} - 1) - \frac{eA_{be}D_n n_{b0}}{x_{bc} - x_{be}} (e^{eV_{bc}/k_B T} - 1)$$

$$I_E = I_{ES} \left( e^{eV_{be}/k_B T} - 1 \right) - \alpha_R I_{CS} \left( e^{eV_{bc}/k_B T} - 1 \right)$$

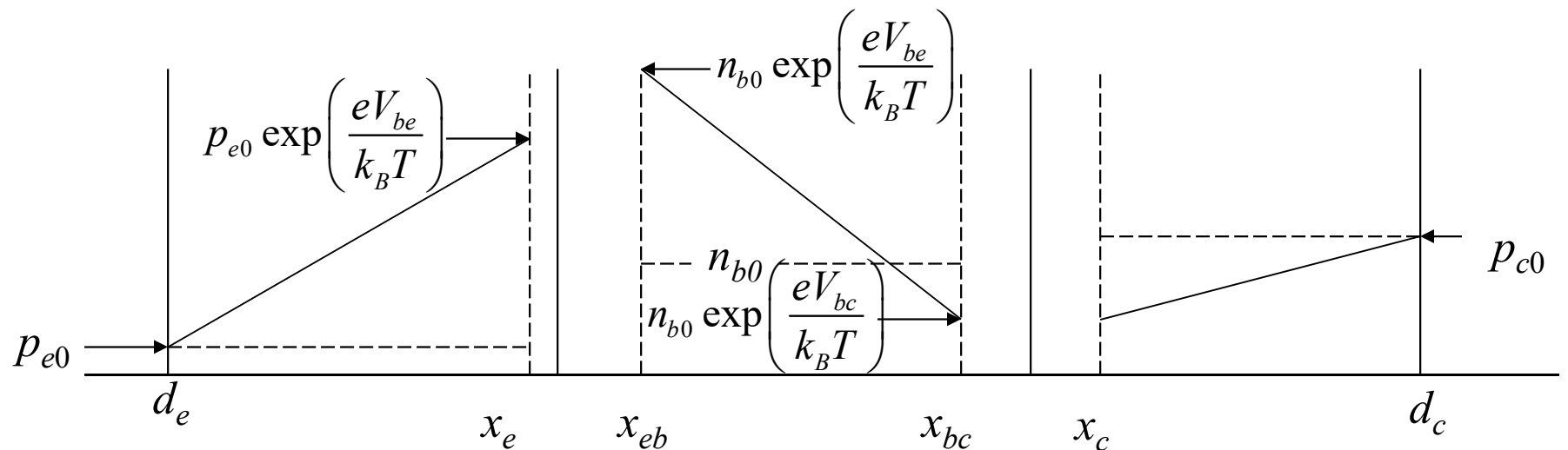

# Collector current

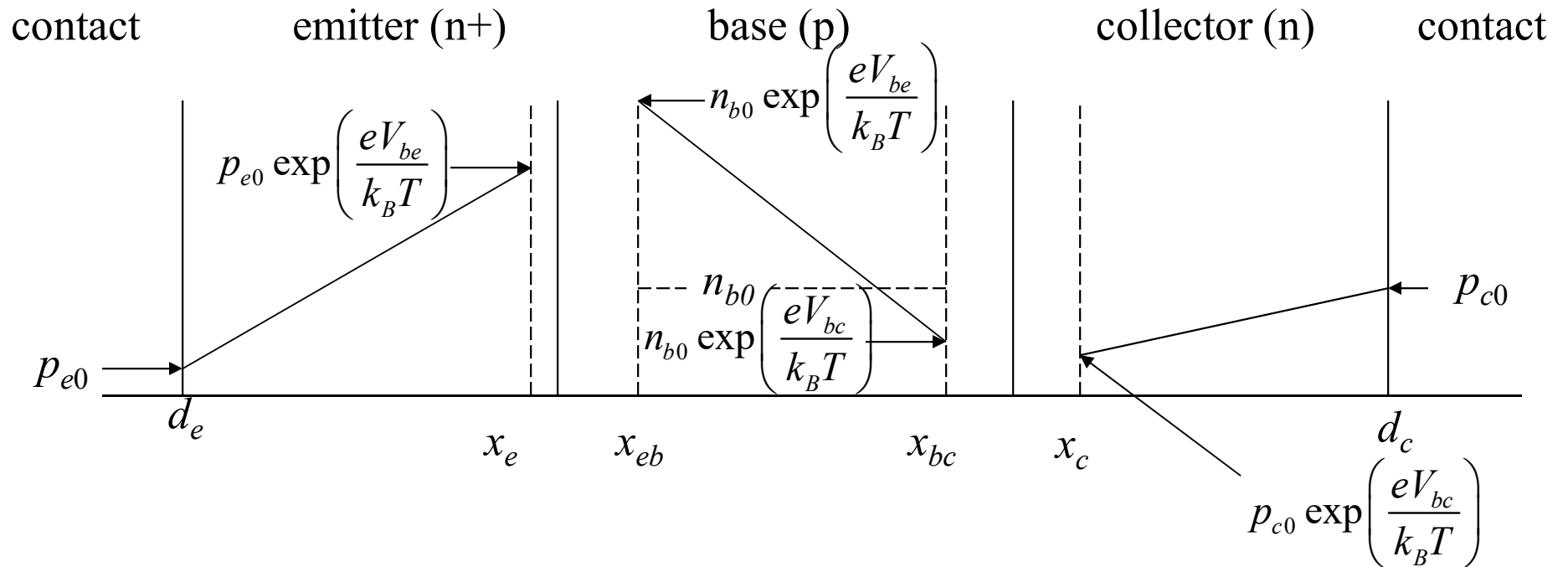

$$I_{cp} = -eA_{bc}D_p \frac{p_{c0}(e^{eV_{bc}/k_B T} - 1)}{d_c - x_c}$$

$$I_{cn} = -eA_{bc}D_n \frac{n_{b0}(e^{eV_{be}/k_B T} - e^{eV_{bc}/k_B T})}{x_{bc} - x_{eb}}$$

# Collector current

$$I_c = I_{cp} + I_{cn} = \frac{eA_{bc}D_n n_{b0}}{x_{bc} - x_{be}} (e^{eV_{be}/k_B T} - 1) - \left[ \frac{eA_{bc}D_p p_{c0}}{d_c - x_c} + \frac{eA_{bc}D_n n_{b0}}{x_{bc} - x_{be}} \right] (e^{eV_{bc}/k_B T} - 1)$$

$$I_c = I_{cp} + I_{cn} = \alpha_F I_{ES} (e^{eV_{be}/k_B T} - 1) - I_{CS} (e^{eV_{bc}/k_B T} - 1)$$

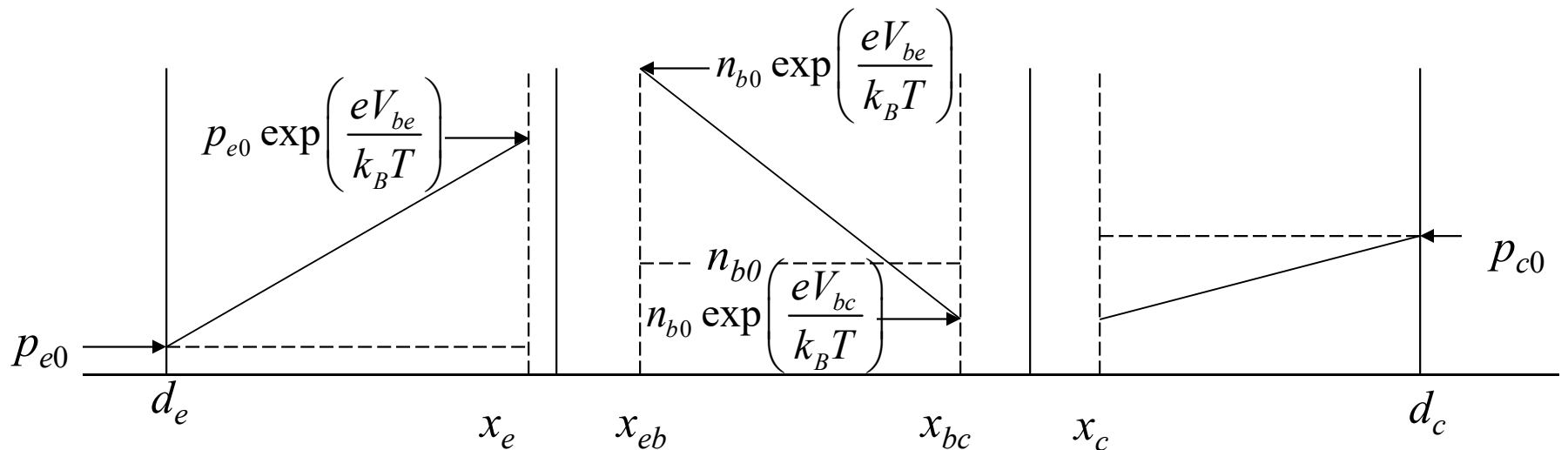

# Ebers-Moll model

$$I_E = I_{ES} \left( e^{eV_{be}/k_B T} - 1 \right) - \alpha_R I_{CS} \left( e^{eV_{bc}/k_B T} - 1 \right)$$

$$I_C = \alpha_F I_{ES} \left( e^{eV_{be}/k_B T} - 1 \right) - I_{CS} \left( e^{eV_{bc}/k_B T} - 1 \right)$$

$$I_B = I_E - I_C$$

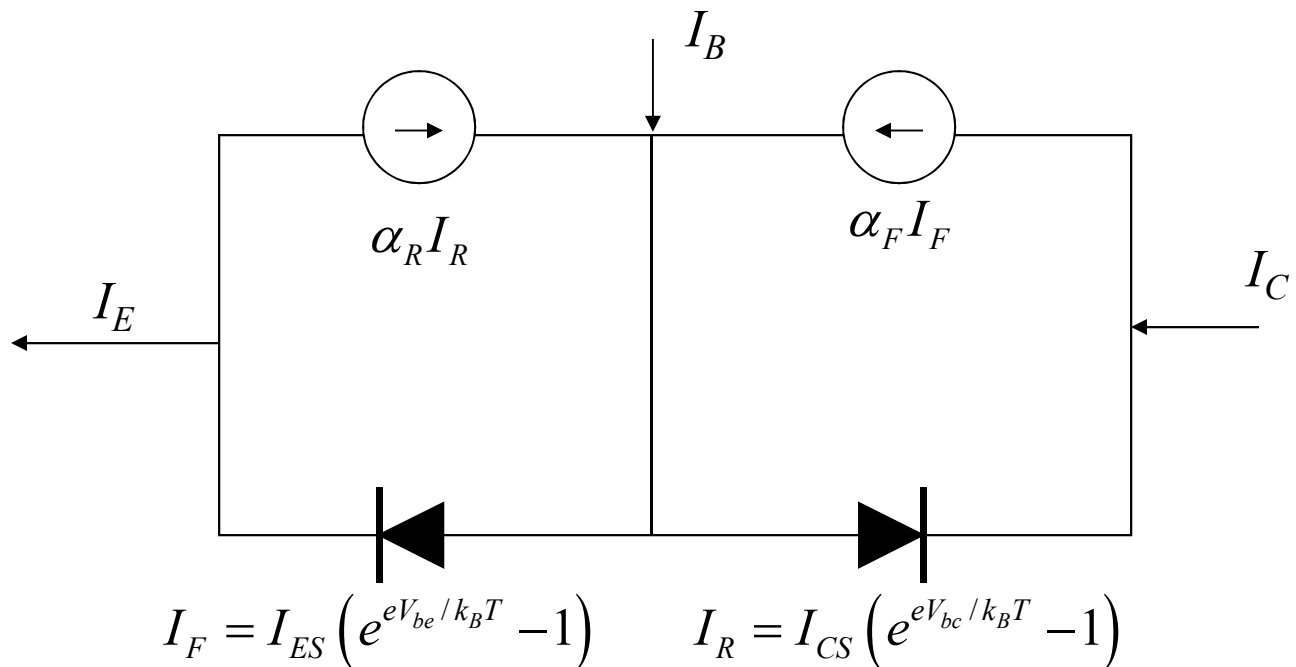

# Transistor modes

1. Forward active: emitter-base **forward**, base-collector **reverse**
2. Saturation: emitter-base **forward**, base-collector **forward**
3. Reverse active: emitter-base **reverse**, base-collector **forward**
4. Cut-off: emitter-base **reverse**, base-collector **reverse**

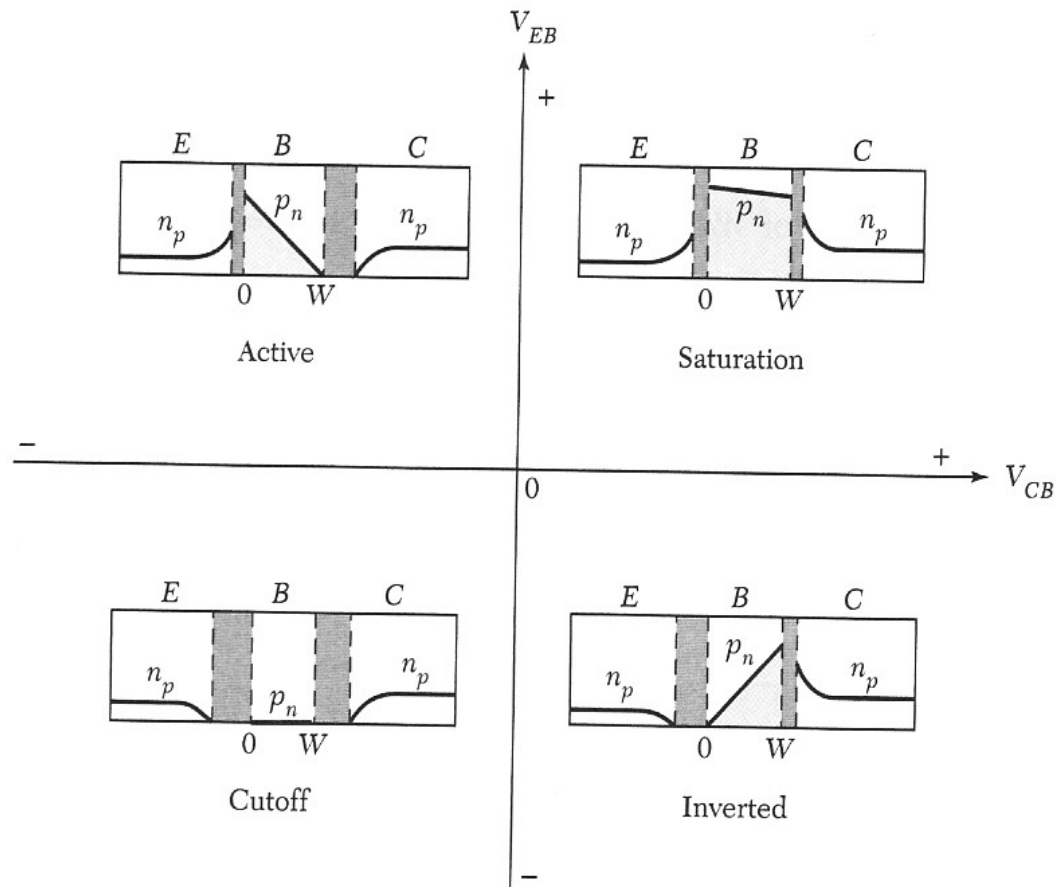

# Common base configuration

$$I_E = I_{ES} \left( e^{eV_{be}/k_B T} - 1 \right) - \alpha_R I_{CS} \left( e^{eV_{bc}/k_B T} - 1 \right)$$

solve for  $V_{be}$

$$I_C = \alpha_F I_{ES} \left( e^{eV_{be}/k_B T} - 1 \right) - I_{CS} \left( e^{eV_{bc}/k_B T} - 1 \right)$$

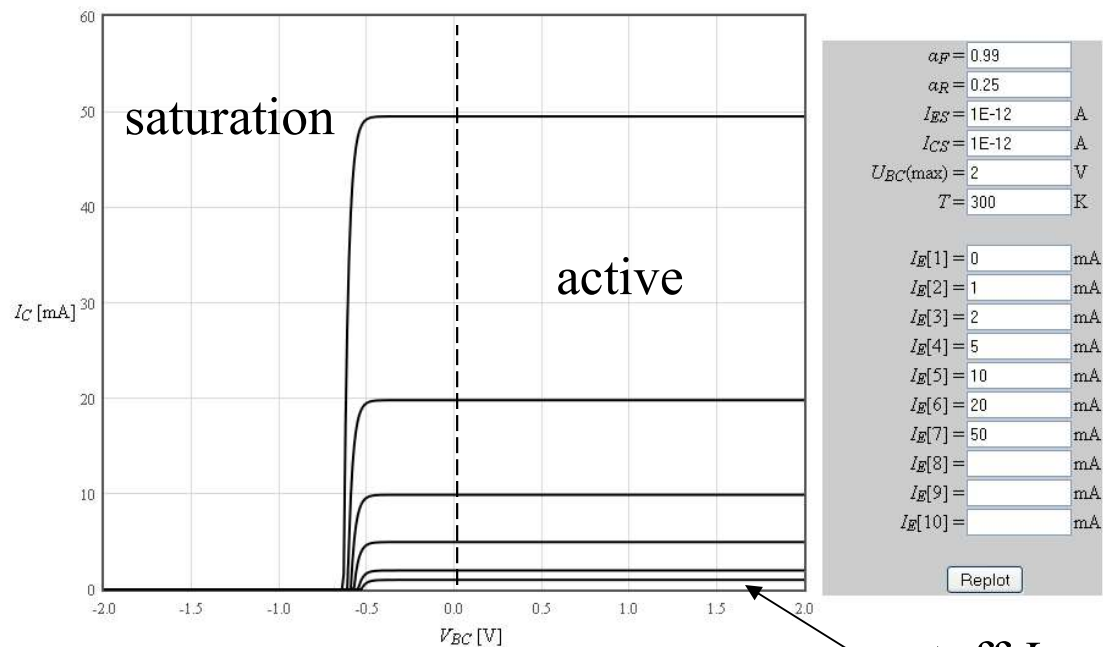
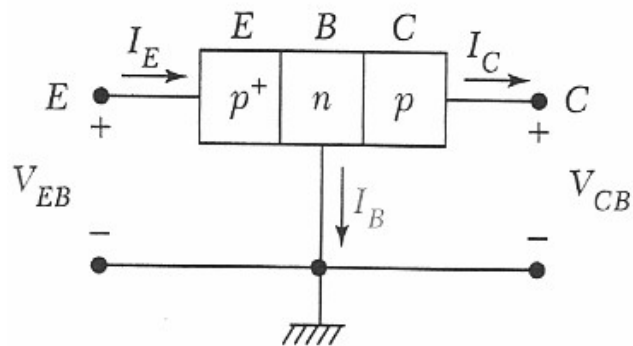

cutoff  $I_E < 0$



# Common emitter configuration

$$I_E = I_{ES} \left( e^{eV_{be}/k_B T} - 1 \right) - \alpha_R I_{CS} \left( e^{eV_{bc}/k_B T} - 1 \right) \quad I_B = I_E - I_C$$

$$I_C = \alpha_F I_{ES} \left( e^{eV_{be}/k_B T} - 1 \right) - I_{CS} \left( e^{eV_{bc}/k_B T} - 1 \right)$$

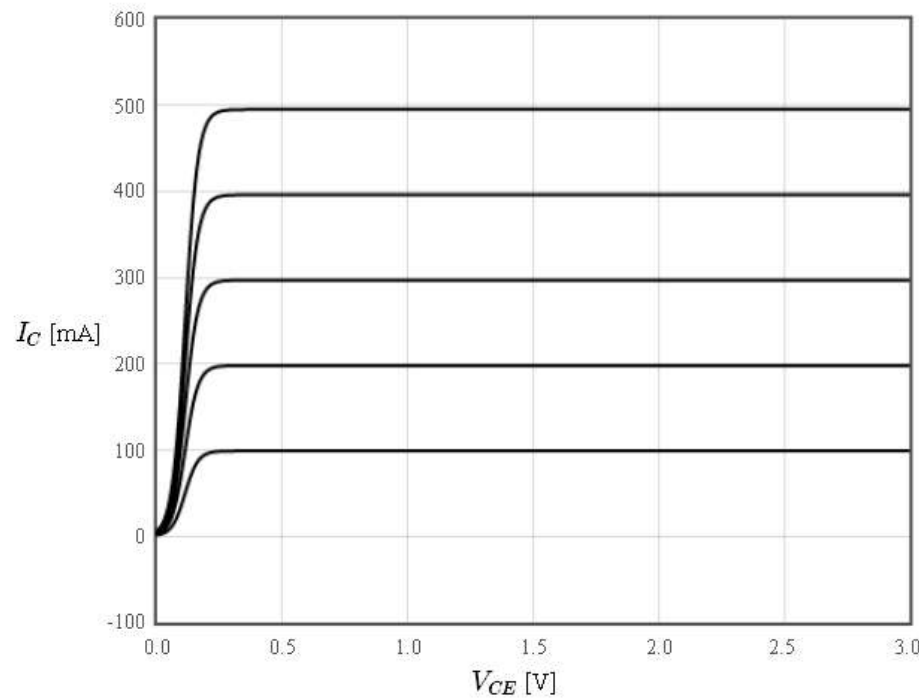
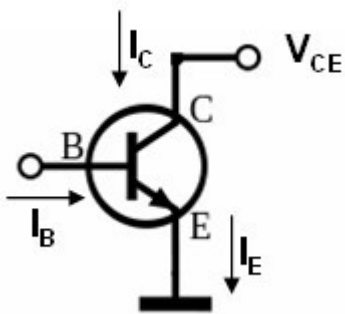

$\alpha_F = 0.99$   
 $\alpha_R = 0.25$   
 $I_{ES} = 1\text{E-}12$  A  
 $I_{CS} = 1\text{E-}12$  A  
 $V_{CE(\text{max})} = 3$  V  
 $T = 300$  K

$I_B[1] = 1$  mA  
 $I_B[2] = 2$  mA  
 $I_B[3] = 3$  mA  
 $I_B[4] = 4$  mA  
 $I_B[5] = 5$  mA  
 $I_B[6] =$  mA  
 $I_B[7] =$  mA  
 $I_B[8] =$  mA  
 $I_B[9] =$  mA  
 $I_B[10] =$  mA

Replot

current amplification  $\sim 100$

# Emitter efficiency

$$\gamma_e = \frac{I_{En}}{I_{En} + I_{Ep}} = \frac{1}{1 + I_{Ep} / I_{En}} \quad \leftarrow \text{for npn}$$

$$I_{Ep} = eA_{be}D_p \frac{p_{e0}(e^{eV_{be}/k_B T} - 1)}{x_{eb} - d_e}$$

$$I_{En} = -eA_{be}D_n \frac{n_{b0}(e^{eV_{be}/k_B T} - e^{eV_{bc}/k_B T})}{x_{bc} - x_{be}}$$

For  $\gamma_e \sim 1$ ,  $x_{bc} - x_{be} \ll L_b$ ,  $x_{eb} - d_e$  and  $n_{b0} \gg p_{e0}$

neutral base width

$$\frac{n_i^2}{N_{Ab}}$$

$$\frac{n_i^2}{N_{De}}$$

Small base width and heavy emitter doping

# Base transport factor

---

$$B = \frac{I_c}{I_{En}}$$

ratio of the injected current to the collected current

recombination in the base would reduce the base transport factor

A thin base with low doping results in a base transport factor  $\sim 1$

# Current transfer ratio

---

$$\alpha = \frac{I_C}{I_E} = B\gamma_e$$

$\alpha \sim 1$  for a good BJT

# Current amplification factor

---

$$\beta = h_{fe} = \frac{I_C}{I_B}$$

$$I_B = I_E - I_C$$

$$I_C = \alpha I_E$$

$$I_B = \left( \frac{1}{\alpha} - 1 \right) I_C$$

$$\beta = \frac{I_C}{I_B} = \frac{\alpha}{1 - \alpha} = \frac{B\gamma_e}{1 - B\gamma_e}$$

$$\beta \sim 50 - 500$$

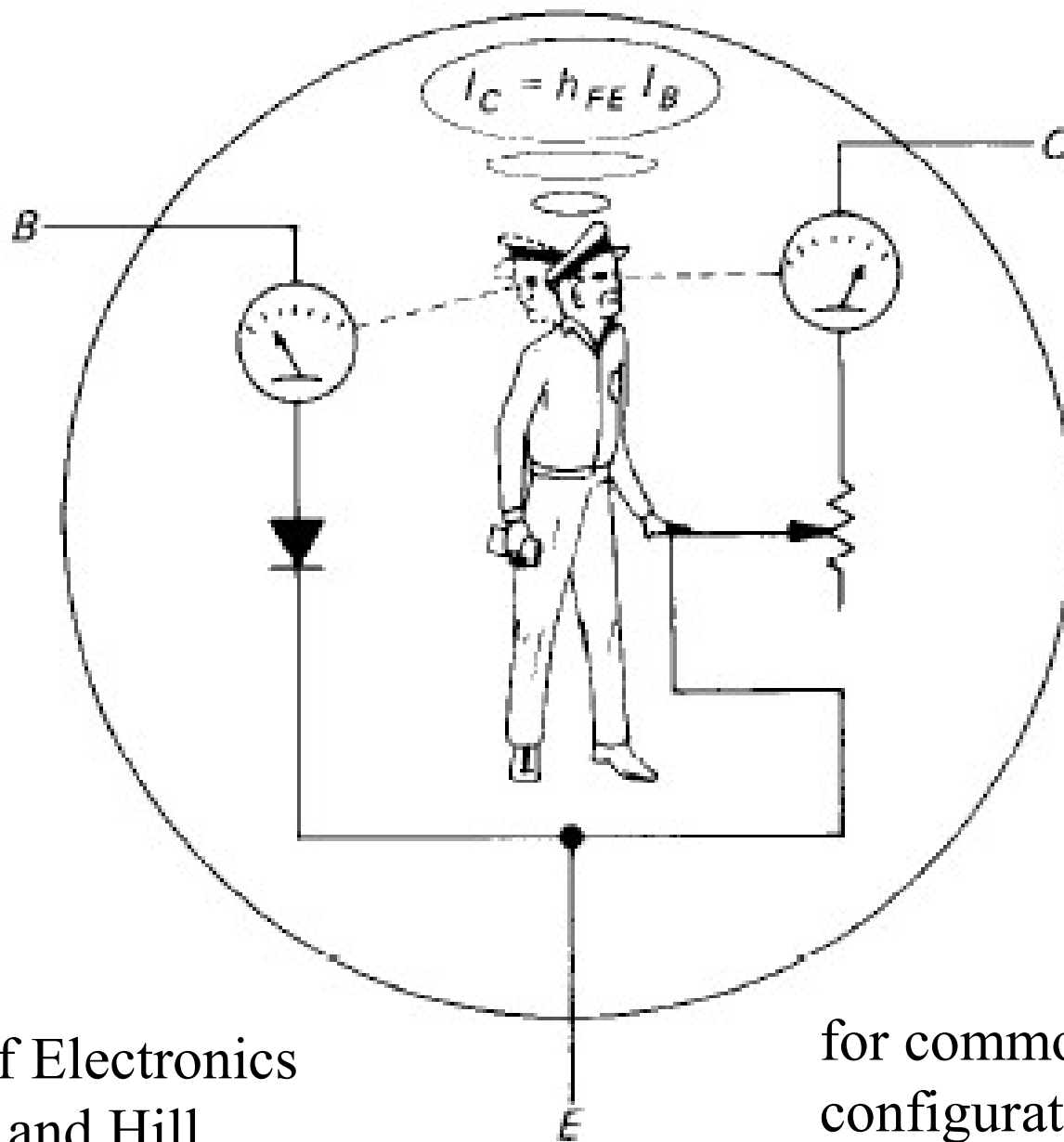

The Art of Electronics  
Horowitz and Hill

for common emitter  
configuration

“Transistor man”

# Transconductance

---

$$g_m = \frac{\partial I_C}{\partial V_{be}}$$

$$I_c = \alpha_F I_{ES} \left( e^{eV_{be}/k_B T} - 1 \right) - I_{CS} \left( e^{eV_{bc}/k_B T} - 1 \right)$$

The first term depends on  $V_{be}$

$$g_m = \frac{e\alpha_F I_{ES}}{k_B T} e^{eV_{be}/k_B T} \approx \frac{eI_C}{k_B T} = \frac{e\beta I_B}{k_B T}$$

The transconductance can be very high.

# Early effect

Ebers - Moll:

$$I_E = I_{ES} \left( e^{eV_{be}/k_B T} - 1 \right) - \alpha_R I_{CS} \left( e^{eV_{bc}/k_B T} - 1 \right)$$

$$I_C = \alpha_F I_{ES} \left( e^{eV_{be}/k_B T} - 1 \right) - I_{CS} \left( e^{eV_{bc}/k_B T} - 1 \right)$$

$$I_B = I_E - I_C$$

$$I_{ES} = \left[ \frac{eA_{be}D_p p_{e0}}{x_{eb} - d_e} + \frac{eA_{be}D_n n_{b0}}{x_{bc} - x_{be}} \right]$$

$$I_{CS} = \left[ \frac{eA_{bc}D_p p_{c0}}{d_c - x_c} + \frac{eA_{bc}D_n n_{b0}}{x_{bc} - x_{be}} \right]$$

$I_{ES}$  and  $I_{CS}$  are treated as constants but the depletion widths  $W_{bc}$ ,  $W_{be}$ ,  $W_c$  and  $W_e$  depend on the voltages.

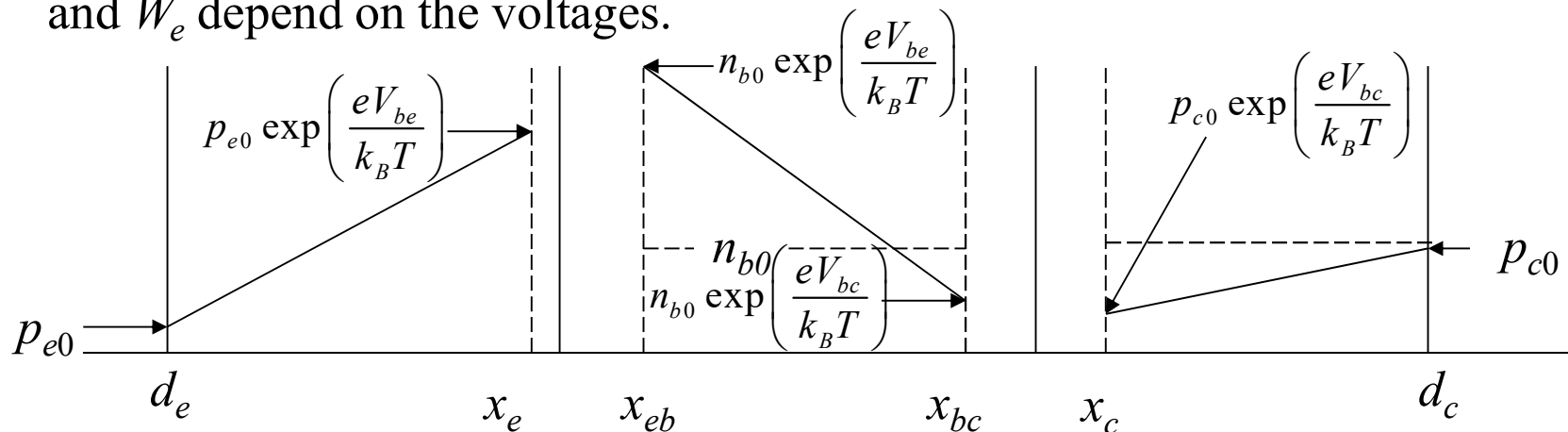



# Minority carrier concentration

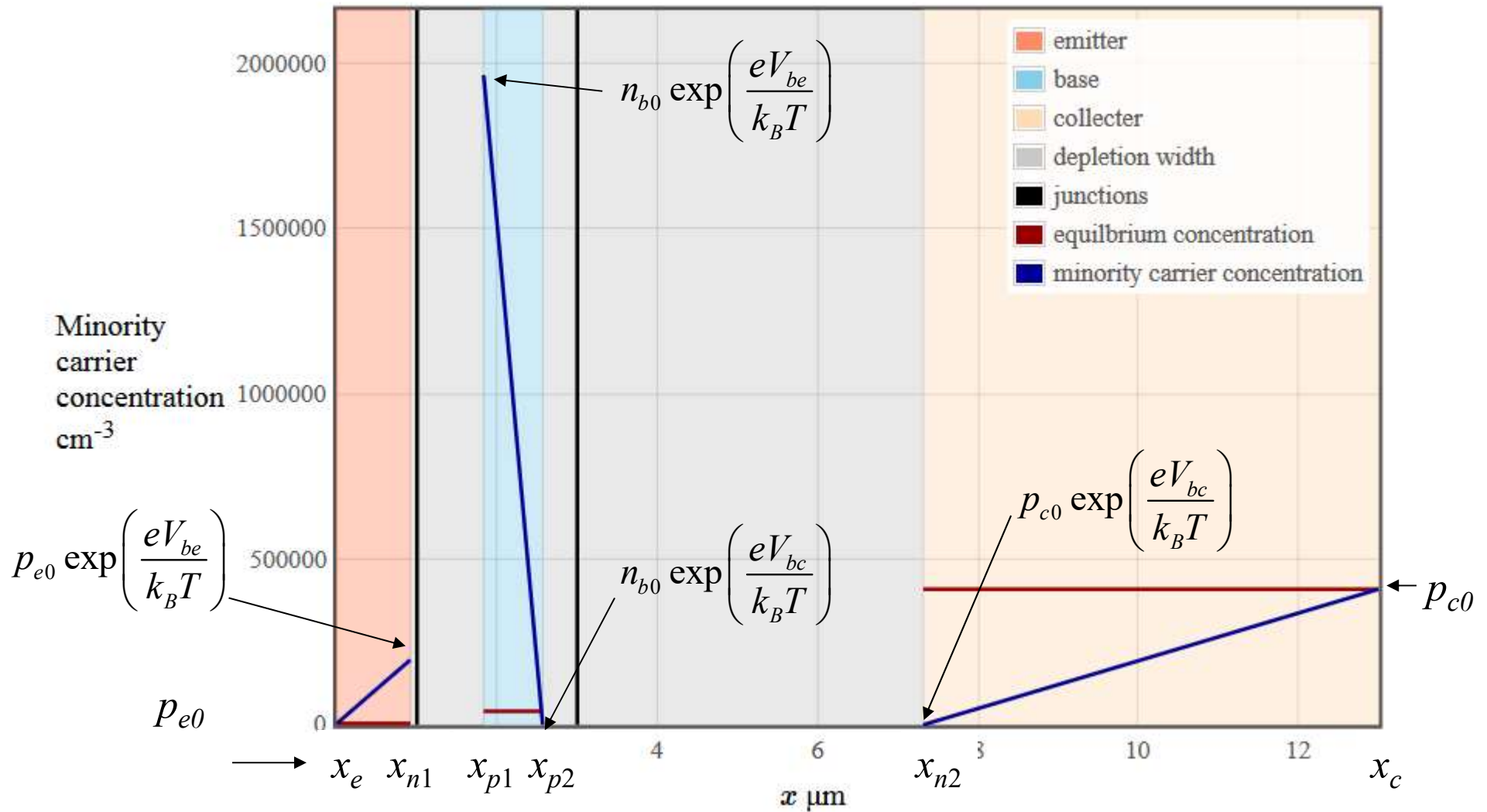

# Early effect

---

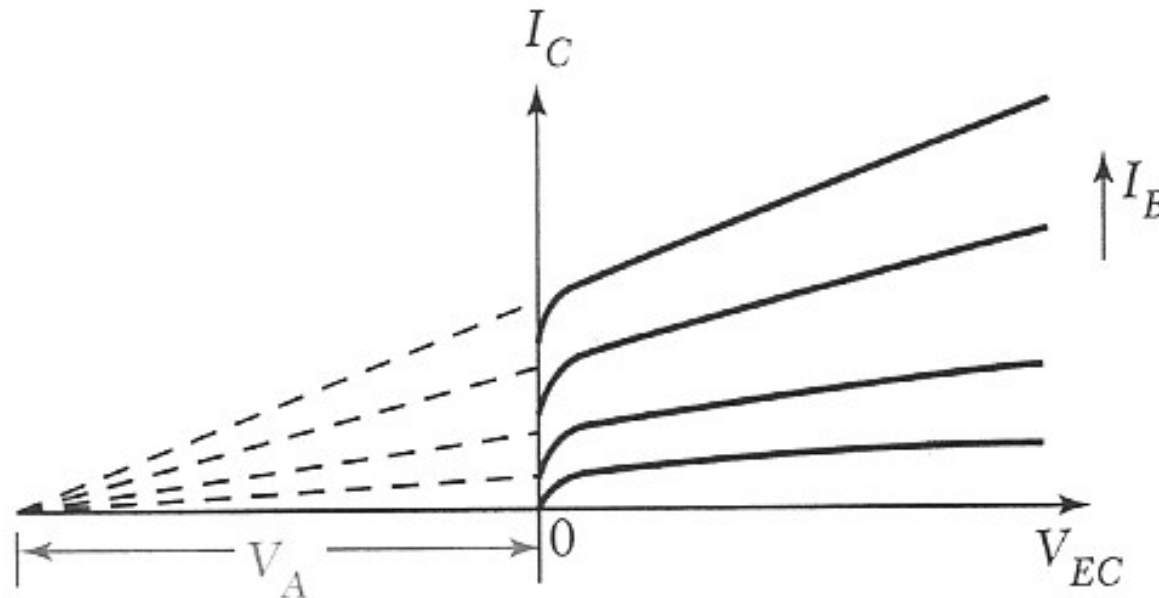

Common emitter configuration

Base width modulation: smaller width increases the diffusion current and increases the gain.

Punchthrough: The neutral base width goes to zero and all gain is lost.

Lightly dope the collector -> voltage drops in collector. Makes circuit slower.

## NPN common emitter configuration

n-Emitter		$A_{cb} = 1E-3$ cm <sup>2</sup>	
Minority $\mu_{pe} = 480$ cm <sup>2</sup> /Vs	$N_{de} = 1E16$ cm <sup>-3</sup>	$N_c(300K) = 2.78E19$ cm <sup>-3</sup>	$N_v(300K) = 9.84E18$ cm <sup>-3</sup>
$\tau_{pe} = 1E-5$ s		$E_g = 1.166-4.73E-4*T*(T+636)$ eV	$\epsilon_r = 11.9$
p-Base		$I_{bmax} = 0.001$ eV	$V_{ce max} = 12$ eV
Minority $\mu_{nb} = 1350$ cm <sup>2</sup> /Vs	$N_{db} = 1E15$ cm <sup>-3</sup>	$x_1 - x_e = 1$ μm	$x_2 - x_1 = 2$ μm
$\tau_{nb} = 1E-5$ s		$x_c - x_2 = 10$ μm	$T = 300$ K
n-Collector		Calculate	
Minority $\mu_{pc} = 480$ cm <sup>2</sup> /Vs	$N_{dc} = 1E14$ cm <sup>-3</sup>		
$\tau_{pc} = 1E-5$ s			

$$I_C \sim \beta I_B$$

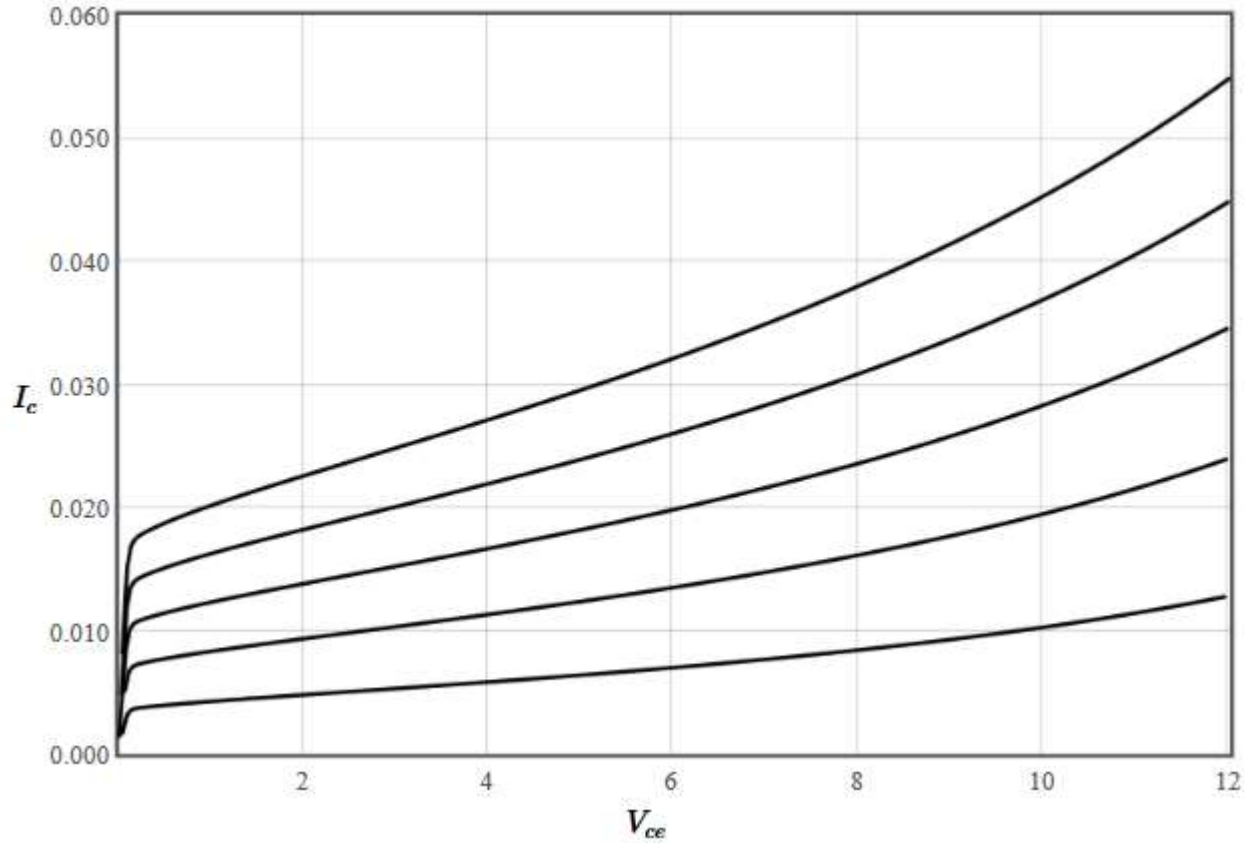

# Common emitter configuration

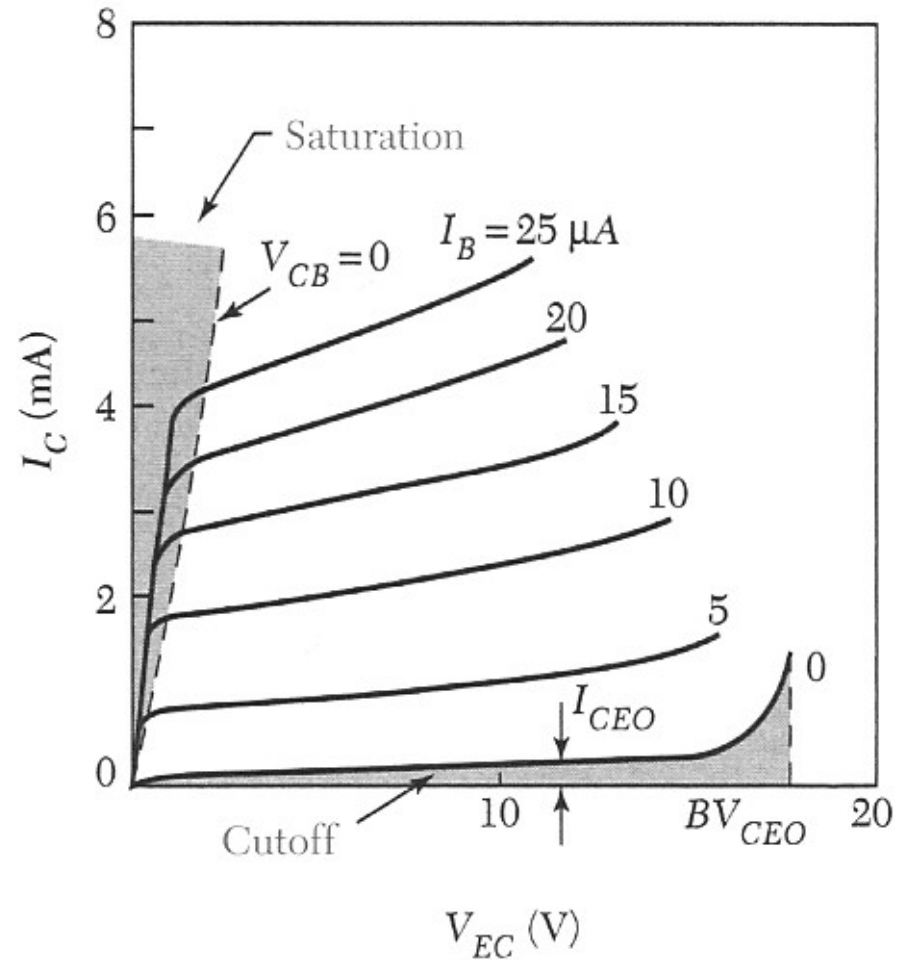
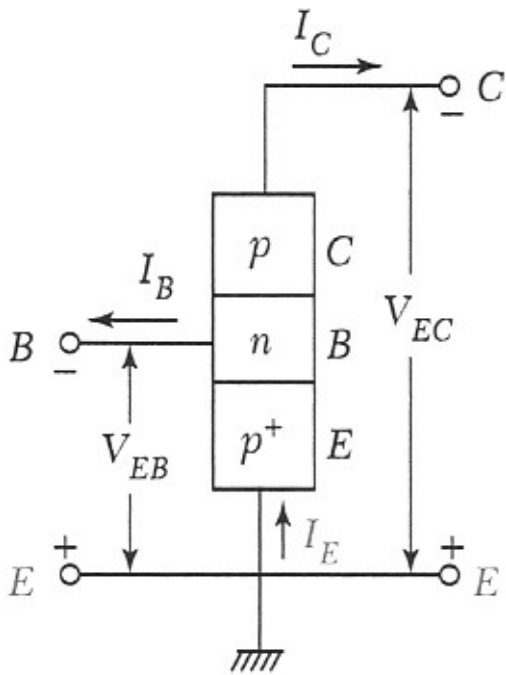

$$I_C \sim \beta I_B \text{ amplifier}$$

# Not an npn transistor

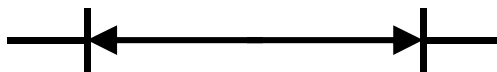
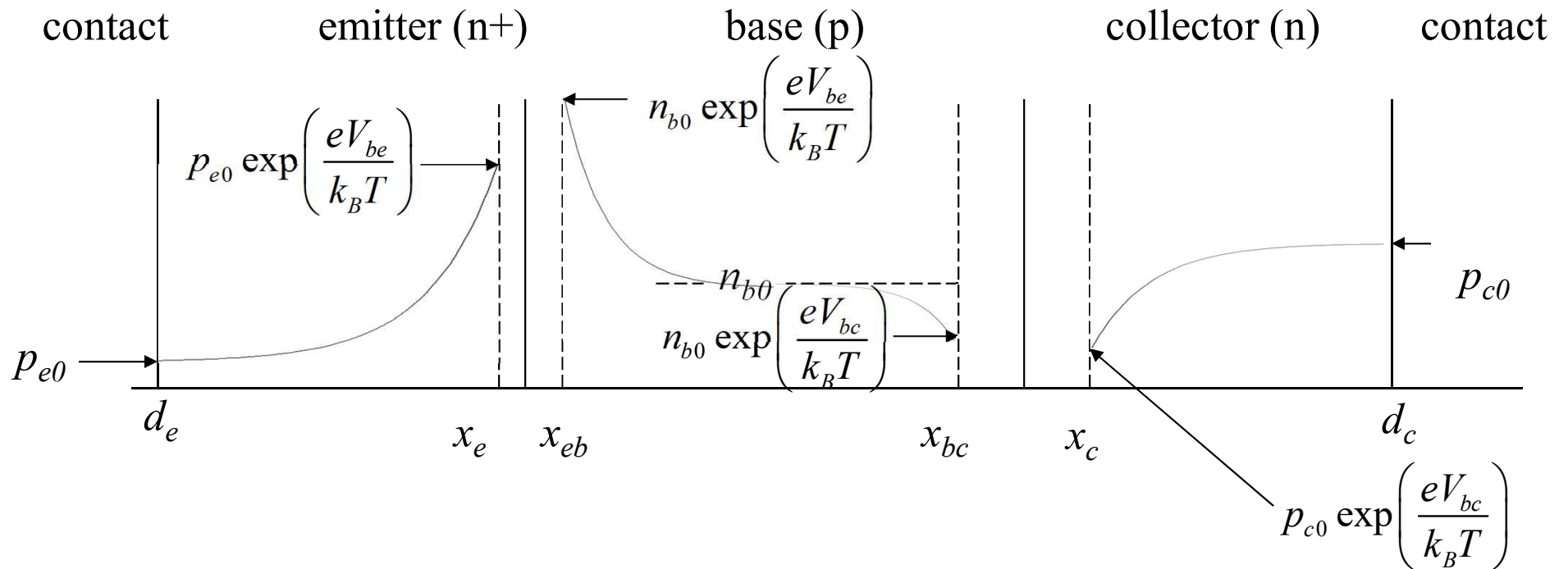

# Small signal response

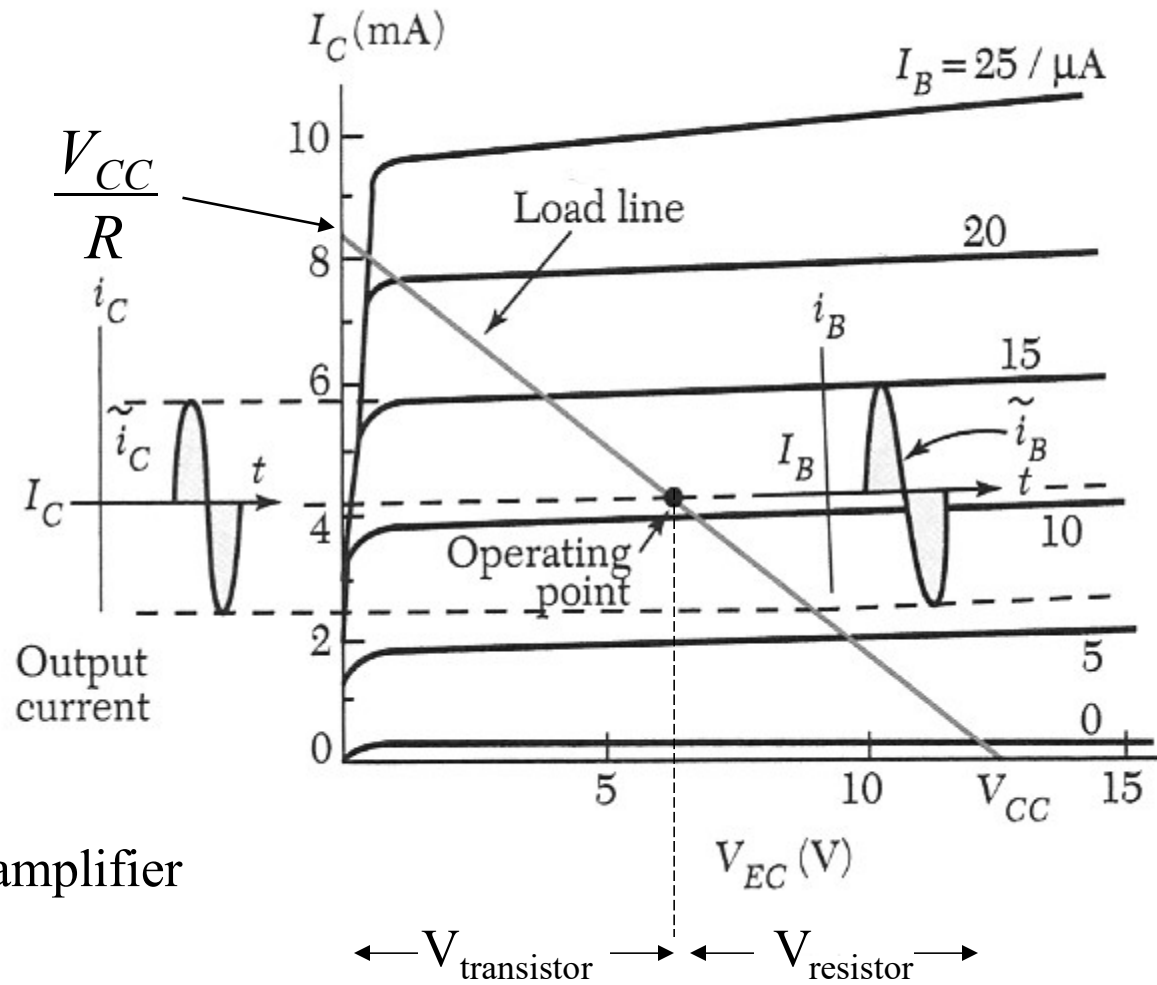
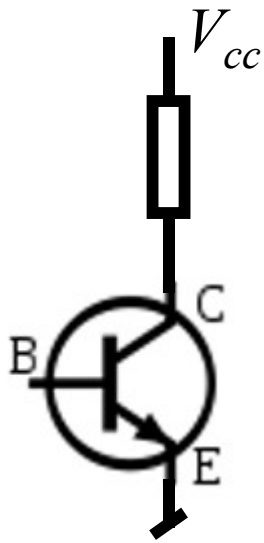

Low input impedance amplifier

# Small signal response

$$\tilde{i}_c = \beta \tilde{i}_B = \beta g_{EB} \tilde{v}_{EB}$$

input conductance:

$$g_{EB} = \frac{\tilde{i}_B}{\tilde{v}_{EB}}$$

transconductance:

$$g_m = \frac{\tilde{i}_c}{\tilde{v}_{EB}}$$

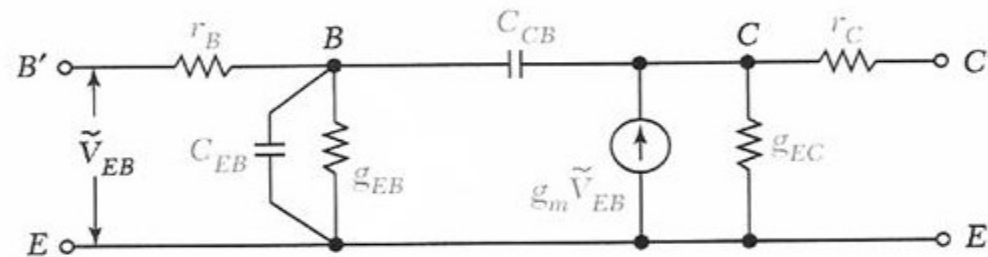
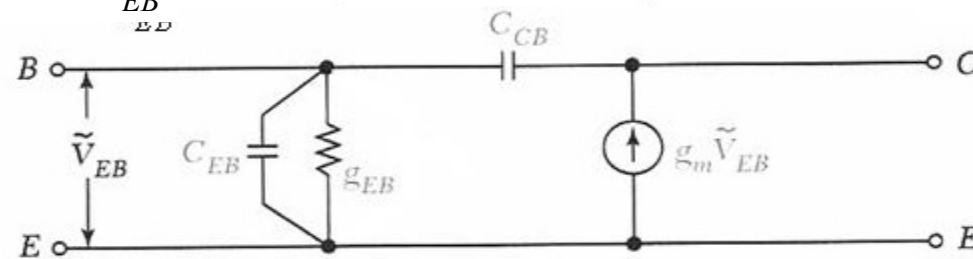
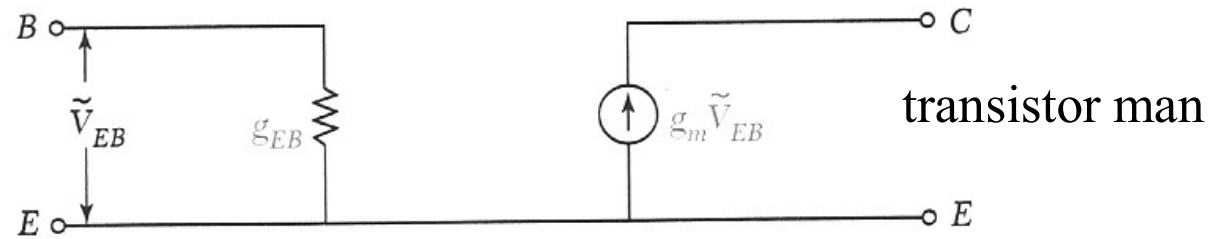

# Small signal response

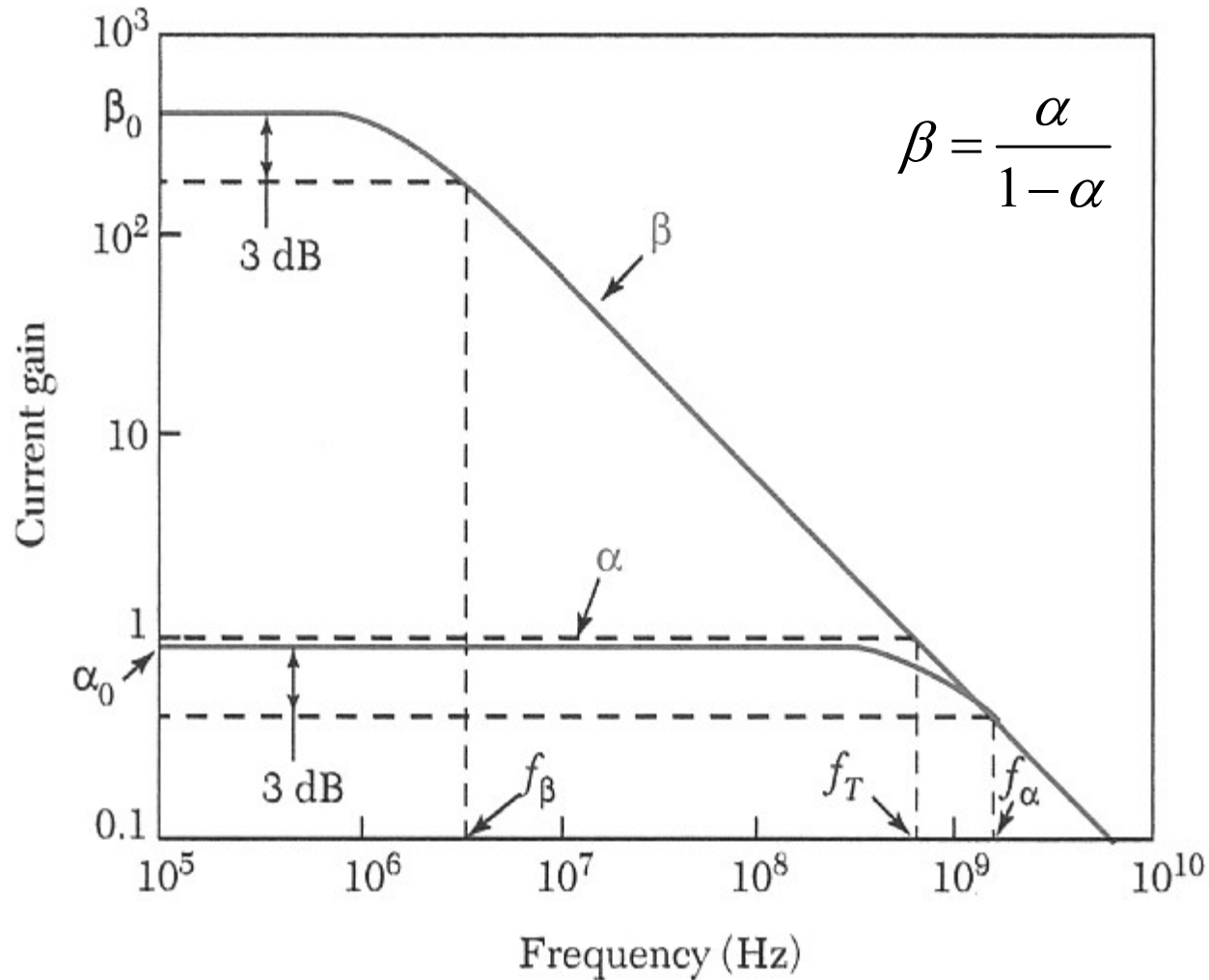

$$f_\beta = (1 - \alpha_0) f_\alpha$$

$$f_T = \alpha_0 f_\alpha$$



# Heterojunction bipolar transistors

